



**SNOWBLOWER
OPERATORS
AND
PARTS MANUAL**

**MANUFACTURED BY:
SMYTH WELDING & MACHINE SHOP LTD.
R.R.#2
37452 GLEN'S HILL RD.
AUBURN, ONTARIO
N0M 1E0
TEL: (519) 529-7212
FAX: (519) 529-3277**

INTRODUCTION

Thank you for choosing a *Smyth Welding* snowblower. We are confident this equipment will meet your requirements in terms of quality, performance and reliability.

This manual was made to help you in the safe operation of your new snowblower. It contains important information which will help you operate your snowblower and help it perform to its fullest capabilities.

Please read this manual completely before operating your snowblower and keep it for future reference.

Before starting the machine, you or any other person who will be operating the snowblower must familiarize yourself with the safety recommendations and the operating instructions. Please read carefully and be sure to understand and follow all recommendations and procedures.

If you require additional information on your snowblower, please contact your *Smyth Welding* dealer.

Now take this moment to enter the serial number (on the silver sticker on the back of the unit) and date of purchase on your snowblower on the “important information” sheet.

When ordering parts from your dealer please refer to these numbers. Use *Smyth* parts for replacements.

Important Information

This manual has been prepared to provide the owner and operator with the information required to properly operate and maintain their unit. It is important that you, the owner or operator read this manual prior to operating or performing any maintenance work on the unit. This manual is for all snowblower models.

Date of purchase: _____

Serial Number: _____

Information needed for ordering parts.

Model

Number: _____

Special

Options: _____

Warranty Information

Smyth Welding Ltd. products are warranted for a period of twelve (12) months from the original date of purchase, by original purchaser, to be free from defects in material and workmanship under correct, normal agricultural use and proper applications.

Smyth Welding Ltd.'s obligations under this warranty shall be limited to the repair or exchange, at Smyth Welding's option, of any Smyth Welding product or part which proves to be defective as provided. The customer will return his unit to his dealer where it was purchased and if the dealer agrees with the warranty must then notify Smyth Welding to get authorization.

The equipment must be installed (when applicable), operated and maintained in accordance with Smyth Welding's instructions.

This warranty does not extend to goods damaged or subject to accident, abuse or misuse after shipment from Smyth Welding, nor to goods altered or repaired by anyone other than an authorized Smyth Welding representative, nor to bolt on cutting edges.

Smyth Welding shall in no event be responsible for any consequential damages of any nature whether special or general, direct or indirect.

Any warranty or claim which differs from that set out is unauthorized by Smyth Welding Ltd. and is the warranty only of the party making it. Smyth Welding Ltd. makes no other warranty express or implied and the original user's sole remedy for breach thereof is as set forth.

To obtain warranty a copy of original bill of sale is required and all claims must be submitted within a thirty (30) day period from date of failure repair.

SAFETY

General Safety

WHEN YOU SEE THIS SYMBOL



ATTENTION!

This symbol warns you of the possibility of DANGER. Carefully read this manual and follow the recommendations before operating your snowblower.

- 1. Careful operation is the best assurance against accidents. It is the owner's responsibility to make sure that anyone who will operate this snowblower will read this manual before operating this equipment.**
- 2. Familiarize yourself with all controls and always be ready to stop the snowblower quickly in case of emergency.**
- 3. Never let a child operate the snowblower.**
- 4. Do not modify the snowblower. Any non-authorized modifications may affect the efficiency and/or safety of the equipment and will automatically void the warranty.**
- 5. Never operate the snowblower with defective parts or if damaged in any way. Have it repaired before operating.**
- 6. Make sure all fasteners are in place and properly secured or tightened.**
- 7. NEVER wear loose fitting clothing when working with the snowblower. These could get entangled in moving parts of the equipment.**
- 8. Prolonged exposure to noise may hamper hearing. Protect yourself by wearing adequate hearing protection devices.**
- 9. Hydraulic fluids under pressure can damage your skin. Do not use your hands to locate leaks.**
- 10. Before the beginning of the snow season inspect all areas where the snowblower will be used and remove any object which may cause an accident and/or damage the unit.**
- 11. Never operate the snowblower in poor visibility or without proper lighting conditions.**

SAFETY IN OPERATION

- 1. Be sure that there are no obstructions around the equipment and that there is no one standing near the equipment when in operation.**
- 2. Do not operate an engine in a confined or non-ventilated area.**
- 3. Do not perform any adjustments, cleaning, maintenance or repairs with the engine running. The engine must be stopped and the PTO disengaged. Preferably remove the key from the ignition.**
- 4. Adjust skid shoes for proper ground clearance of the cutting edge.**
- 5. Before operating make sure the PTO is properly installed and secured.**
- 6. Before starting the snowblower make sure the auger and drum areas are free of ice.**
- 7. Put the PTO control in the neutral position before starting the engine.**
- 8. Keep hands, feet and clothing away from the moving parts of the snowblower. Stay away from the discharge chute.**
- 9. Before performing maintenance or repairs such as unplugging the chute, always disengage the PTO, stop the engine and relieve all hydraulic pressures.**
- 10. Do not operate in excessive inclined areas. Be careful when turning on slopes.**
- 11. Never operate your snowblower with missing guards or without protective devices in place.**
- 12. Do not operate your snowblower near buildings, windows or other vehicles without proper and prior adjustment to the chute deflector.**
- 13. Never aim the discharge chute towards people or animals. This may cause serious injury.**
- 14. Always reduce operating speed in slippery conditions.**
- 15. Be careful when backing-up, make sure you have good visibility.**
- 16. Always be on the look-out for objects which may enter the snowblower.**
- 17. If undue vibrations are felt, disengage the PTO, stop the engine and look for causes of vibration. Vibration is usually the indicator of a problem.**
- 18. At the end of operation, disengage the PTO, lower the snowblower, put the transmission in neutral, apply parking brake, stop the engine and remove the key from the ignition.**
- 19. NEVER perform any work under the snowblower while it is supported only by the tractor's hydraulic system. It must be completely supported by wooden blocks or other safety means.**

DECALS

Safety Decals are affixed wherever special safety precautions are indicated. Locate them on your machine and read them carefully. If a decal is damaged, lost or illegible, install a new one.



****Observe the correct PTO speed.
DO NOT exceed the correct PTO
speed. PTO speed is 540 rpm on all models
except 108HD which is 1000 rpm.**

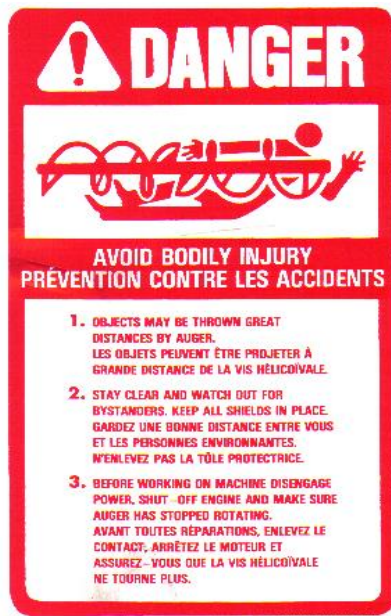

Snowblower augers are very aggressive – NEVER leave the tractor with the PTO engaged to unclog, or to kick material into the auger.

Maintenance

Stop the unit, disengage the PTO drive and completely shut down the tractor engine with the snowblower set on the ground or completely unhooked from the tractor before doing any adjustments or service.

Installing New Chain

Before installing new chain carefully check the teeth on the sprocket. If the teeth are worn to a hooked shape, the sprockets should be replaced to assure full capacity performance and a satisfactory life from the new chain. Tight chain causes an additional load which increases wear on chain joints, sprockets and shaft bearings. Slack chain produces vibration, which may result in excessive chain wear, noise or shock loading.

Tighten chain allowing ¼" sag in the bottom span as the chain wears.

Sprocket Inspection

Check for these common sprocket problems which lead to replacement.

- 1. Wear on the sides, which is due to misalignment.**
- 2. Tooth wear (indicated by hooking).**
- 3. Broken teeth.**
- 4. Cracks that might lead to failure.**
- 5. Wobbling of sprockets on shaft.**

Grease – Bearings

For the best results, the grease should be pumped into the bearings slowly until a very slight bead of grease forms around the bearing seals on the shaft. This bead, in addition to acting as an indication of adequate lubrication, provides extra protection against entry of foreign material. To prevent premature failure, always make sure the grease zerk, grease gun tip, and the grease are clean and free of any dirt, grit, paint or foreign material.

Shear bolts

Shear bolts are built to break under shocks on the fan or on the auger. However, under certain circumstances, this security is not adequate. Example: A sudden high impact shock on the fan may, in some cases, break the fan shaft without breaking the shear bolt.

If the shear bolt breaks, make sure to always replace it with a same category bolt (**grade 5** for PTO series **20-40-50-60**, and **grade 8** for PTO series **80**). It is necessary to always maintain this bolt very tight, in order to keep the efficiency of the shearing mechanism.

WARNING:

The gearbox fan shafts are made with a special alloy steel. Moreover, they are case hardened to increase capacity to shock load. These shafts cannot be broken under normal snow loads. However, undesirable objects may enter the fan and either bend or break the gearbox shaft. It is understood that the gearbox cannot be built to resist every possible overloads, and consequently, gearbox fan shafts **will not be replaced under warranty**. Therefore, the user of the snowblower must be **very careful**.

Maximum length of PTO shaft

WARNING:

Telescopic tubes of PTO should overlap a minimum length to meet ideal conditions for power transmission.

Following table could be used as a guide to find the maximum permissible length of PTO:

Description of P.T.O.	Over-all length		Telescopic tubes overlap
	Closed	Opened max.	
T20-056P	29:3/4"	41"	5"
T40-056P	30:1/2"	40:1/2"	6"
T50-071P	36:1/2"	50"	7"
T60-086P	37:3/4"	51:1/4"	7"
T80-066P	36"	47:1/4"	7"

Installation Instructions for Better PTO Shaft & Gearbox Operation

A proper initial installation will give you years of satisfactory service on your equipment. Please read carefully the following instructions, which have been specially made to help you and your satisfaction with your purchase.

WARNING: Unfortunately, the snowblower will be faced with forgotten or hidden objects under the snow, such as, chain, tires, stones, pieces of wood, etc...In spite of our snowblower's strength and durability, they are not built to handle all of these conditions.

Danger: Tractor Too Large

It is dangerous to use a tractor, which is too big or too powerful. The tractor may be able to overload the blower, even if the machine is already at maximum capacity. If the tractor is too high, extreme angles at PTO shaft universal joints will result, and the life of these U-joints will be shortened dramatically.

PTO Shaft Angles

PTO shafts are made to transmit power with angles at universal joints. However, these angles should be kept to a minimum. The larger the angle, the shorter the life of the PTO shaft. Take for example a snowblower made for a tractor capacity of 60-70HP, which would be attached to a 60HP tractor, operating at maximum capacity (60HP continuous).

H.P.
60 @ 540 RPM

P.T.O. angles
5°
10°
15°
20°
25°

Estimated life in hours
450 hours
195 hours
90 hours
40 hours
20 hours

How to determine P.T.O. angle

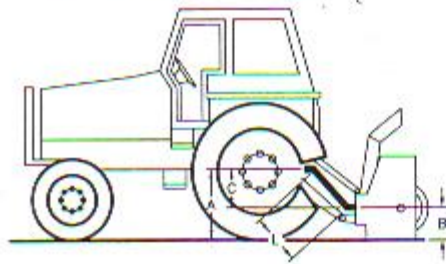

- A** = P.T.O. height at tractor
B = P.T.O. height at blower
C = A - B
L = Cross center distance in working position

- 1) Lower blower on ground.
- 2) Take measures A, B & L
- 3) Subtract B of A ($A - B = C$)
- 4) Divide L by C ($L \div C = F$)
- 5) Compare F Factor in table below to find P.T.O. angle (interpolate, if necessary).

F FACTOR	ANGLE
6	10°
3.75	15°
2.75	20°
2.15	25°
1.75	30°

Previous examples clearly demonstrate that universal joint angle is directly related with life of P.T.O.. In order to reduce angle, it is necessary to increase the distance between snowblower and tractor.

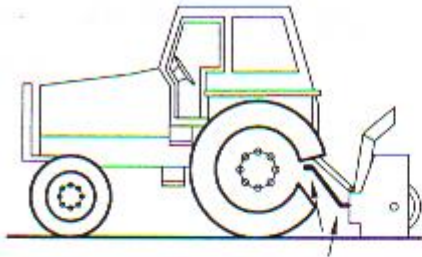

TOO LARGE ANGLES AT P.T.O. JOINTS
TO AVOID

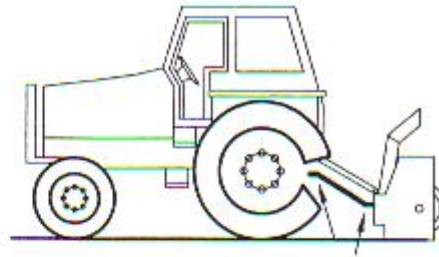

REASONABLE ANGLES AT P.T.O. JOINTS
ACCEPTABLE

If it is impossible to increase the distance between snowblower and tractor, in order to maintain a reasonable angle at P.T.O., it is recommended to use a larger size of P.T.O., that is a greater capacity P.T.O. (please refer to your dealer for more details).

For snowblowers of 100 H.P., an additional gearbox is also available that can be mounted on existing snowblower gearbox, which increases the input shaft height, reducing angle at P.T.O. joints. This gearbox also has an input speed of 1000 R.P.M., which greatly increases P.T.O. capacity.

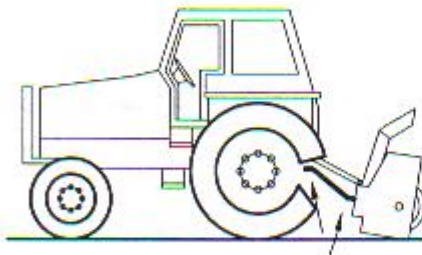

NON-EQUAL ANGLES AT P.T.O. JOINTS
TO AVOID

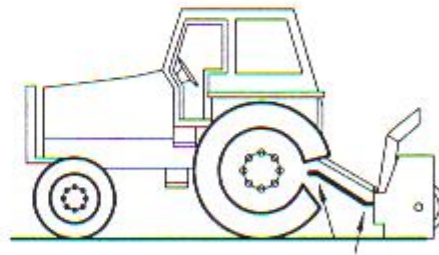

EQUAL ANGLES AT P.T.O. JOINTS
RECOMMENDED

Angles at each end of P.T.O.

A popular habit is to change snowblower angle in order to obtain a better scraping effect. This practice can become harmful to the P.T.O., angle at each end being unequal. There will be a fan speed variation as well as a drastic increase of load on cross and bearings. **To avoid.** It is recommended to keep tractor P.T.O. shaft and snowblower input shaft always parallel.

<i>Snowblower Size</i>	<i>Chain</i>	<i>Idler</i>	<i>Sprockets</i>	<i>Bearing/Flangettes</i>
48", 54" & 60"	#50 – 48" long	S150B17 x 5/8"	50A36 x 1"	(3) – 1" UC bearing with grease fitting & flangettes
66", 72" & 78"	#60 -61" long	S160B15 x 5/8"	60A38 1-3/8 with 4 holes	(1) 1-1/4" bearing & flangettes (2) 1-3/8" 4 bolt flange
84"	#60 -71" long (S) #60-84" long (D)	S160B15 x 5/8"	60A38 1-3/8 With 4 holes	(1) 1-1/4" bearing & flangettes (2) 1-3/8" 4 bolt flange (4 for (D) double auger)
96"	#60H -71" long (S) #60H -84" long (D)	S160B15 x 5/8"	60A38 1-3/8 with 4 holes	(1) 1-1/4" bearing & flangettes (2) 1-3/8" 4 bolt flange (4 for (D) double auger)
102"	#80 -83" long (S)	S180A11H x 3/4"	80A32 x 1-3/8 With 4 holes	(1) 1-3/4" bearing & flangettes (2) 1-3/8" 4 bolt flange (4 for (D) double auger)
108"	#80H -111" long	S180A11H x 3/4"	80A32 x 1-3/8 with 4 holes	(1) 1-3/4" bearing & flangettes (2) 1-3/8" 4 bolt flange (4 for (D) double auger)

Snowblower Size:	Gear Box	PTO	Spline Coupler (sleeve)	Shear Pin Sprocket (shear coupler unit)
48", 54" & 60"	L25A	T-20-056	052.030	50SB12H x 1" 50
66", 72" & 78"	T281A	T-40-056	0.267.7102 1-1/4"	60SB12H 1-1/4"
84"	T27D	T-50-071	0.267.7102 1-1/4"	60SB12H 1/4"
96"	T27D	T60	0.267.7102 1-1/4"	60SB12H 1/4"
102" & 108"	T279A	T80	0.279.700HT 1-3/4"	80SB14H 1-3/4"
108" (1000 rpm)	Chain box 1000 rpm	High horse power 540rpm uses V80 PTO	0.279.700HT 1-3/4"	80SB14H 1-3/4"

Snowblower Size	Outer PTO Tube	Inner PTO Tube	Shear Pins	Oil Seals	Metric Cross Kit
48", 54" & 60LS	4mm x 29mm #2 AP29.3	3.2mm x 36mm #2 AP36.3	PTO 6mm x 40mm (1/4" x 1-1/2") Auger: 1/4 x 1"	25 x 47 x 7	23.8 x 61.2 AP2.20
66", 72" & 78"	4.5mm x 36mm #4 AP36.4	3.4mm x 43.5mm x #3 & 4 AP43.3	PTO 8mm x 50mm (5/16 x 2) Auger: 1/4 x 1-1/2"	35 x 52 x 7	27 x 70mm AP 3.11
84"	4mm x 45mm #5 & 6 AP45.4	3mm x 51.6mm #6 AP52.3	PTO 10mm x 55mm (3/8 x 2") Auger: 5/16 x 1-1/2"	35 x 72 x 10 40 x 80 x 12	30.2 x 80mm AP5.00
96"	4mm x 45mm #5 & 6 AP45.4	3mm x 51.6mm #6 AP52.3	PTO 10mm x 60mm #6 Auger: 5/16 x 1-1/2"	35 x 72 x 10 40 x 80 x 12	30.2 x 9.2mm AP6.22
102" & 108"	4mm x 54mm #8 AP54.4	4mm x 63mm #8 & 9 AP63.4	PTO 12mm x 65mm (1/2" x 2-1/2) Auger: 5/16 x 1-1/2"	50 x 72 x 8 52 x 85 x 10 45 x 72 x 8	35 x 107mm AP8.24 27 x 74.6mm AP 4.21

SMYTH 48" ,54" & 60" LS SNOWBLOWER

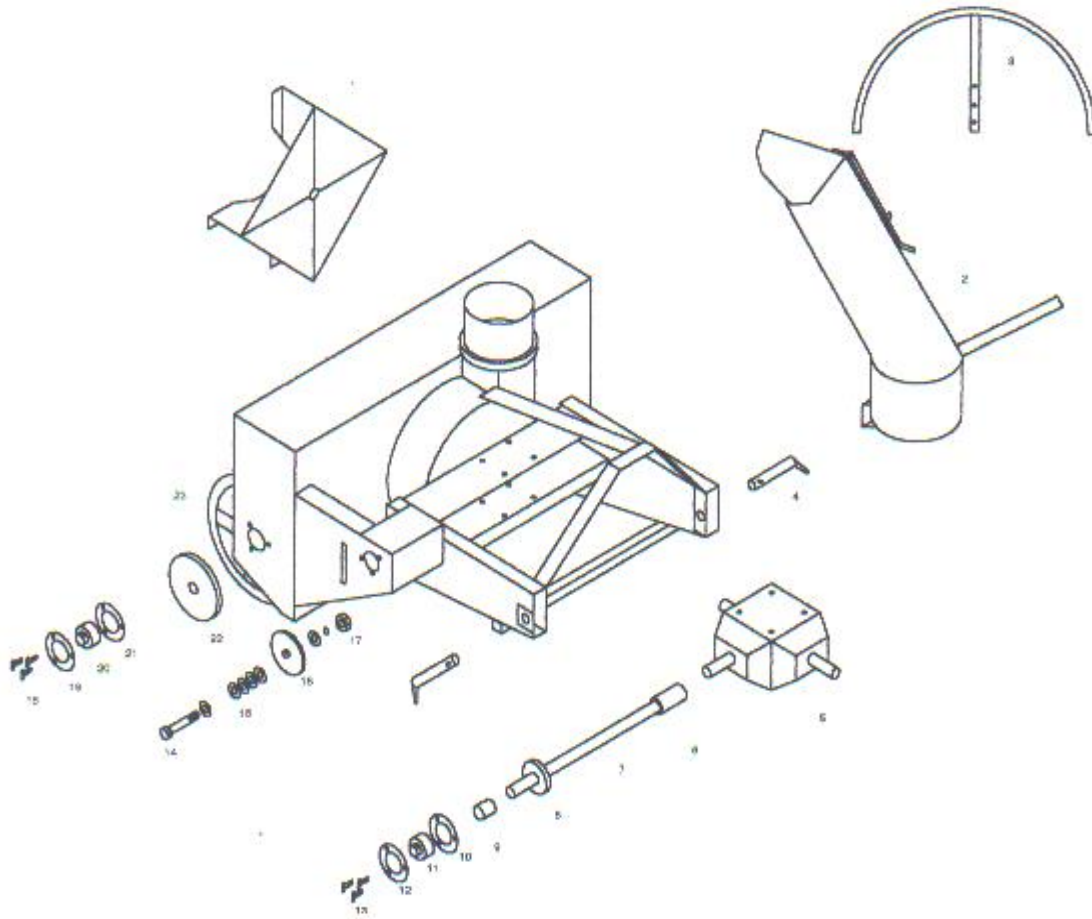

SMYTH 48", 54", & 60LS SNOWBLOWER

- 1. fan**
- 2. hood (w. grease fitting)**
- 3. hood turner**
- 4. hitch pin**
- 5. gearbox L25A**
- 6. spline coupler**
- 7. cross shaft**
- 8. shear coupler (w. grease fitting)**
- 9. spacer**
- 10. flangette**
- 11. bearing**
- 12. flangette**
- 13. bolts**
- 14. 5/8"x 3 1/2" bolt**
- 15. 5/8" flat washers**
- 16. #5017 idler sprocket**
- 17. 5/8" machinery bushing, nut and lockwasher**
- 18. bolts**
- 19. flangette**
- 20. bearing**
- 21. flangette**
- 22. 50A36 sprocket**
- 23. auger**

SMYTH 66", 72" & 78" SNOWBLOWER

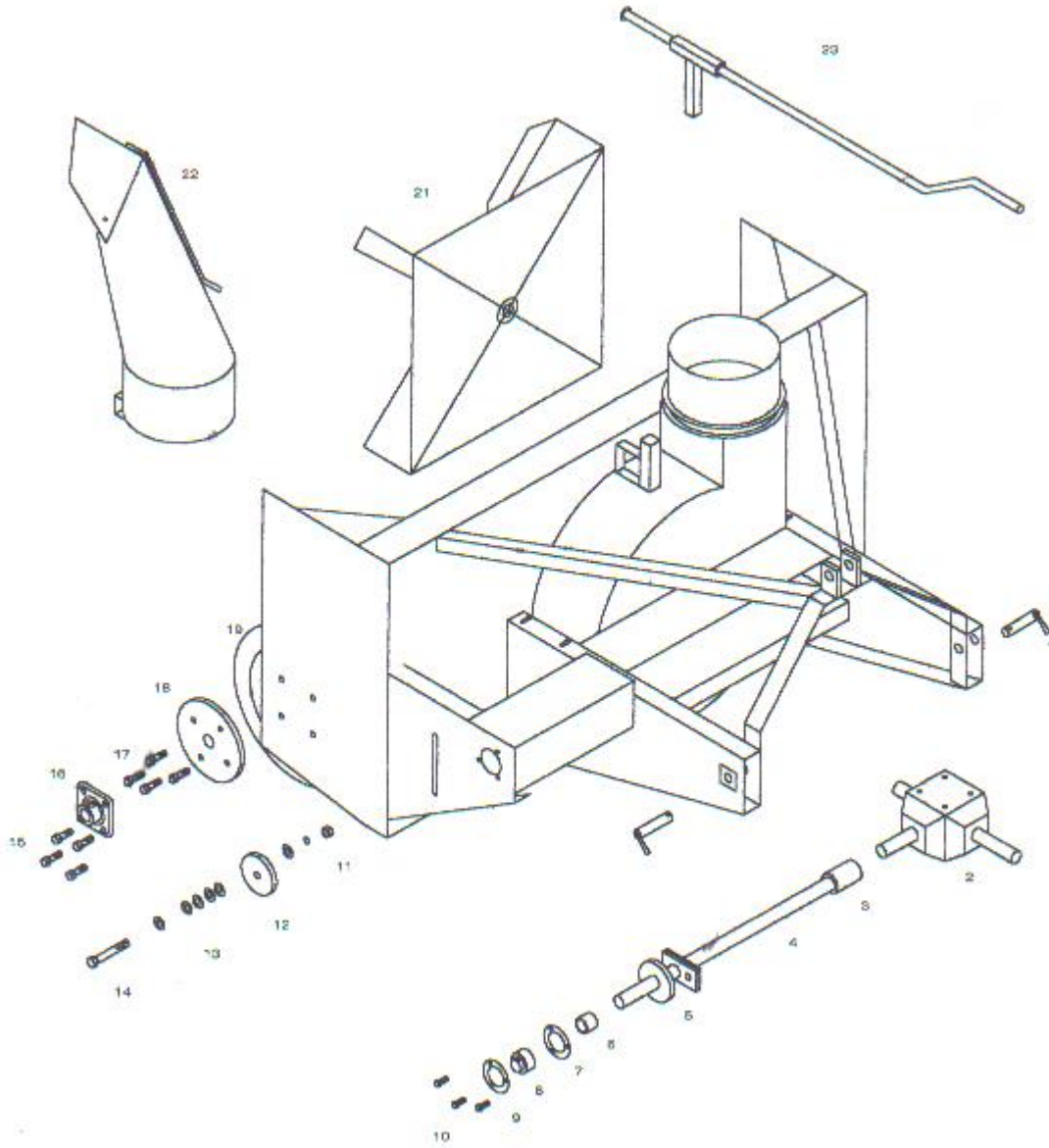

SMYTH 66", 72" & 78" SNOWBLOWER

- 1. hitch pin**
- 2. gearbox T281**
- 3. spline coupler**
- 4. cross shaft**
- 5. shear coupler (w. grease fitting)**
- 6. spacer**
- 7. flangette 207**
- 8. bearing UC 207-20**
- 9. flangette 207 (greaseable) (w. grease fitting)**
- 10. carriage bolts 3/8"x1"**
- 11. 5/8" machinery bushing, nut and lockwasher**
- 12. #6015 idler sprocket**
- 13. 5/8" flat washers**
- 14. 5/8"x3 1/2" bolt**
- 15. 1/2"x 1 1/2" bolts**
- 16. bearing UCF 207-22 (w. grease fitting)**
- 17. 1/2"x1 1/2" bolt**
- 18. 60A38 sprocket**
- 19. 16" auger**
- 21. fan**
- 22. hood (w. grease fitting located at base of hood)**
- 23. hood turner- crank**

SMYTH 84", 96", 102" & 108" SNOWBLOWER

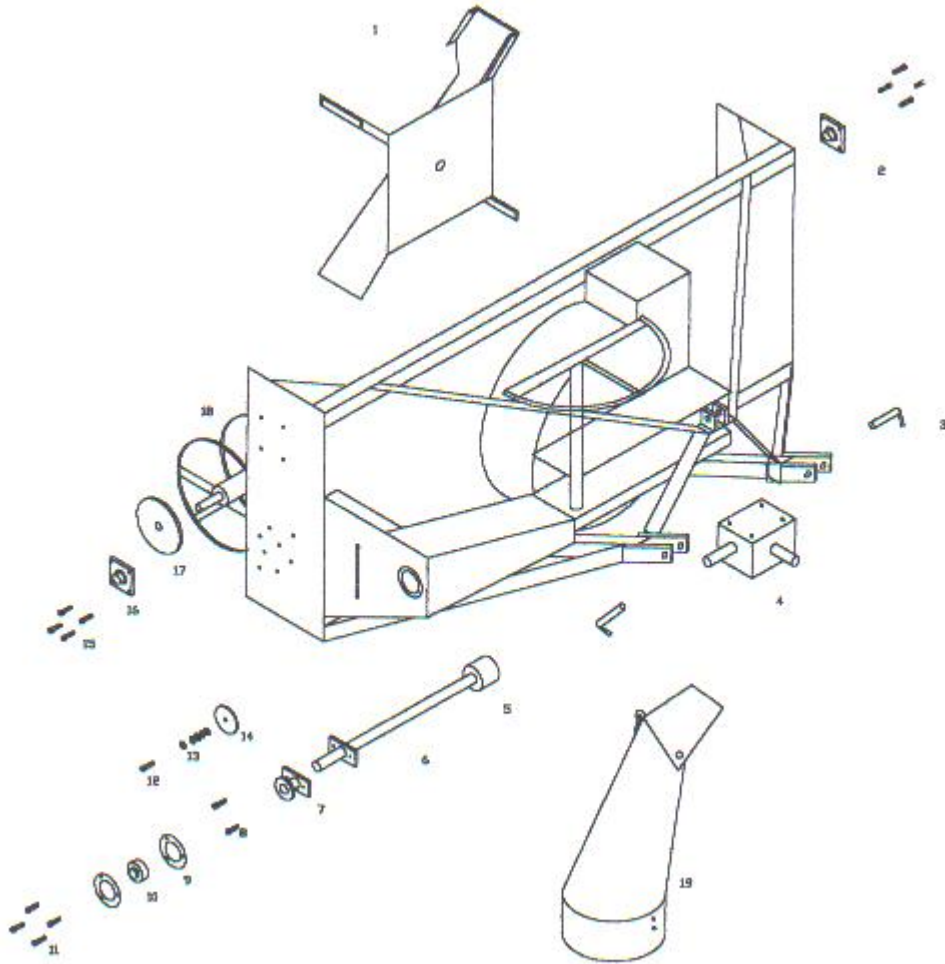

SMYTH 84", 96", 102" & 108" SNOWBLOWER

No.	7'	8'	8 ½'	9'
1.	10"x30" fan	10"x30" fan	12"x30" fan	12"x36" fan
2.	1 3/8"-4 bolt flange UCF 207 106 auger bearing	1 3/8"-4 bolt flange UCF 207 106 auger bearing	1 3/8"-4bolt flange UCF 207 106 auger bearing	1 3/8"-4 bolt flange UCF 207 106 auger bearing
3.	1 1/8"x5" Cat II hitch pin	1 1/8"x5" Cat II hitch pin	1 1/8"x6 ½" Cat II hitch pin	1 1/8"x6 ½" Cat II hitch pin
4.	T-27D gearbox	T-27D gearbox	T-279A gearbox	T-279A gearbox
5.	1 ¾"x19 splined coupler	1 ¾"x19 splined coupler	1 ¾"x20 splined coupler	1 ¾"x20 splined coupler
6.	1 ¼"crx 31 ¾" cross shaft	1 ¼"crx 37 ¾" cross shaft	1 ¾"crx40" cross shaft	1 ¾"crx 43" cross shaft
7.	60SB12H 1 ¼" shear pin sprocket coupler	60SB12H 1 ¼" shear pin sprocket coupler	80SB14H1 ¾" shear pin sprocket coupler	80SB14H 1 ¾" shear pin sprocket coupler
8.	(1) 5/16"x 1 ½" shear pins	(1) 5/16"x1 ½" shear pins	(2) 5/16"x1 ½" shear pins	(2) 5/16"x1 ½" shear pins
9.	(2) 207 flangettes	(2) 207 flangettes	(2) 209 flangettes	(2) 209 flangettes
10.	UC 1 ¾" 207 bearing	UC 1 ¾" 207 bearing	UC 1 ¾" 209 bearing	UC 1 ¾" 209 bearing
11.	(3) 3/8"x1" carriage bolts	(3)3/8"x1" carriage bolts	(4)1/2"x1 ½" carriage bolts	(4)1/2"x1 ½" carriage bolts
12.	5/8"x3 ½" idler bolt	5/8"x3 ½" idler bolt	¾"x4" idler bolt	¾"x4" idler bolt
13.	Spacer washers	Spacer washers	Spacer washers	Spacer washers
14.	S160B15 idler sprocket	S160B15 idler sprocket	S180A11H idler sprocket	S180A11H idler sprocket
15.	(4) ½"x1 ½" bearing bolts	(4) ½"x 1 ½" bearing bolts	(4) ½"x 1 ¾" bearing bolts	(4) ½"x 1 ¾" bearing bolts
16.	1 3/8"-4 bolt flange UCF 207 106 auger bearing	1 3/8"-4 bolt flange UCF 207 106 auger bearing	1 3/8"- 4 bolt flange UCF 207 106 auger bearing	1 3/8"-4 bolt flange UCF 207 106 auger bearing
17.	60A38 auger sprocket	60A38 auger sprocket	80A32 auger sprocket	80A32 auger sprocket
18.	Single-20"x84" auger Double-16"x84" augers	Single-20"x96" auger Double-16"x96" augers	Single-20"x102" auger Double- 16"x102" augers	Single-20"x108" auger Double- 20"x108" augers

66" Pull Type Snowblower Replacement Parts

1. 8" x 24" Fan
2. T281A Gear Box
3. 61" of #60 Auger Drive Chain
4. S160B15 x 5/8" Idler Sprocket
5. #60A38 x 1-3/8" Auger Sprocket
6. #60SB12H 1-1/4" Shear Sprocket
7. (2) UC207-22 -1-3/8" 4 Bolt Flange Auger Bearings
8. (8) 1/2 x 1-3/4" Gr.5 Bolts, Nuts & Lock Washers (For Auger Bearings)
9. UC207-22-1-1/4" Cross Shaft Bearing
10. 90" of 3/16" Cable (2) Cable Clamps (On D-Ring Turner)
11. T40 PTO
12. 67" of 3/8 x 4 flat bar (for cutting edge)
13. (2) 7/8 x 5 Cat. 1 Hitch Pins
14. 1/4 x 1-1/2 bolt Grade 2 or 5 (Shear Bolts for Auger)
15. PTO Shear Pins (8mm x 50) Grade 8.8
16. Oil Seals (35 x 52 x 7)
17. 1-1/4" 19 Spline Coupler

78" Pull Type Snowblower Replacement Parts

1. 8" x 24" Fan
2. T281A Gear Box
3. 61" of #60 Auger Drive Chain
4. S160B15 x 5/8" Idler Sprocket
5. #60A38 x 1-3/8" Auger Sprocket
6. #60SB12H 1-1/4" Shear Sprocket
7. (2) UC207-22 -1-3/8" 4 Bolt Flange Auger Bearings
8. (8) 1/2 x 1-3/4" Gr.5 Bolts, Nuts & Lock Washers (For Auger Bearings)
9. UC207-22-1-1/4" Cross Shaft Bearing
10. 90" of 3/16" Cable (2) Cable Clamps (On D-Ring Turner)
11. T40 PTO
12. 79" of 3/8 x 4 flat bar (for cutting edge)
13. (2) 7/8 x 5 Cat. 1 Hitch Pins
14. 1/4 x 1-1/2 bolt Grade 2 or 5 (Shear Bolts for Auger)
15. PTO Shear Pins (8mm x 50) Grade 8.8
16. Oil Seals (35 x 52 x 7)
17. 1-1/4" 19 Spline Coupler

90" Pull Type Snowblower Replacement Parts

1. 10" x 30" Fan
2. T27D Gear Box
3. 71" of #60 Auger Drive Chain
4. S16015 x 5/8" Idler Sprocket
5. #60A38 x 1-3/8" Auger Sprocket
6. #60SB12H 1-1/4" Shear Sprocket
7. (2) UC207-22 -1-3/8" 4 Bolt Flange Auger Bearings
8. (8) 1/2 x 1-3/4" Gr.5 Bolts, Nuts & Lock Washers (for auger bearings)
9. UC 207-22 -1-1/4" Cross Shaft Bearing
10. 112" of 1/4" Cable (2) 1/4" Cable Clamps (On D-Ring Turner)
11. T50 PTO
12. 91" of 1/2 x 4 flat bar (for cutting edge)
13. (2) 1-1/8 x 5-7/8" Cat. 2 Hitch Pins
14. Auger Shear Bolt (5/16 x 1-1/2 bolt) Grade 2 or 5
15. PTO Shear Bolt (10mm x 55) Grade 8.8
16. Oil Seals (35 x 72 x 10)
17. 1-1/4" 19 Spline Coupler

PART#		
1	SWP-0003	IDLER SPROCKET
2	SWP-0013	SHEAR SPROCKET
3	SB-6024-0001	CROSS SHAFT
4	SWP-0016	HYDRAULIC FLOW DIVIDER
5	SWP-0029	BRACKET
6	SWP-0015	HYDRAULIC MOTOR
7	SWP-0017	GEAR BOX
8	SB-HT-0002	ORBITAL MOUNT BRACKET
9	SWP-0030	HYDRAULIC MOTOR
10	SWP-0003	IDLER SPROCKETS
11	SWP-0034	SPROCKET
12	SWP-0007	CYLINDER
20	SWP-0027	CHAIN COUPLER SPROCKET
21	#60 double roller chain	
22	SWP-0040	CHAIN COUPLER SPROCKET

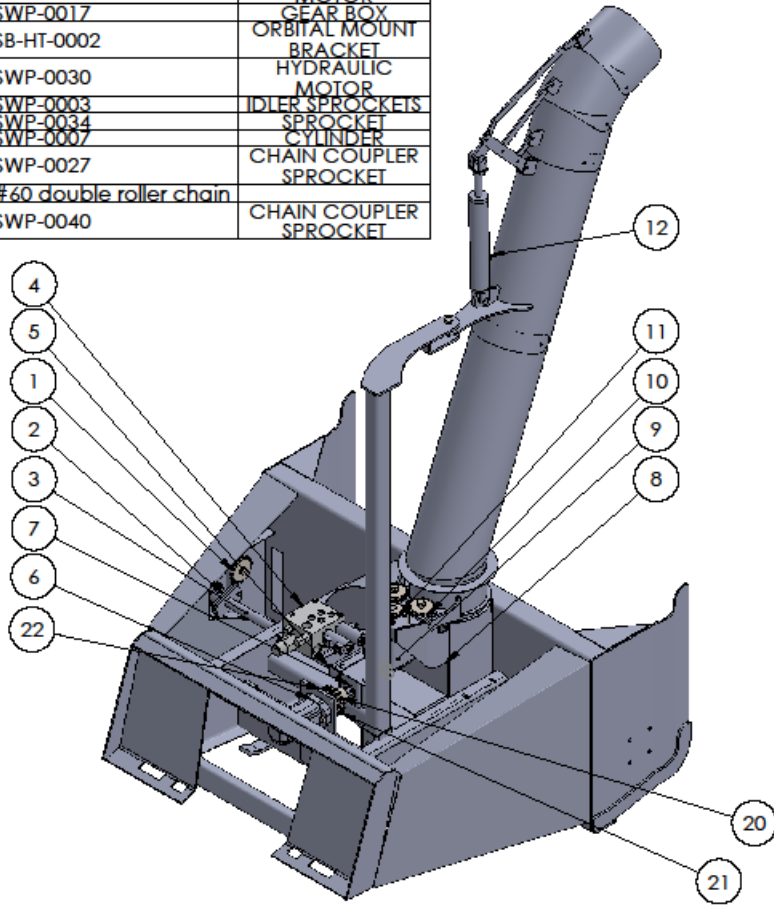

MATERIAL		SMYTH WELDING & MACHINE SHOP LTD. #1-510-520-7212	
QTY	PART#	60-SH-SMYTH HYDRAULIC SNOWBLOWER	REV.
	SCALE:1:50	DATE	SHEET 1 OF 2

	PART #	
13	SWP-0039	FAN
14	SWP-0035	SPROCKET
15	SB-60-0003	AUGER
16	SWP-0019	AUGER BEARING
17	SWP-0038	GRADER BOLTS
18	SWP-0036	CUTTING EDGE
19	#60 ROLLER CHAIN	
20		
21		
22		

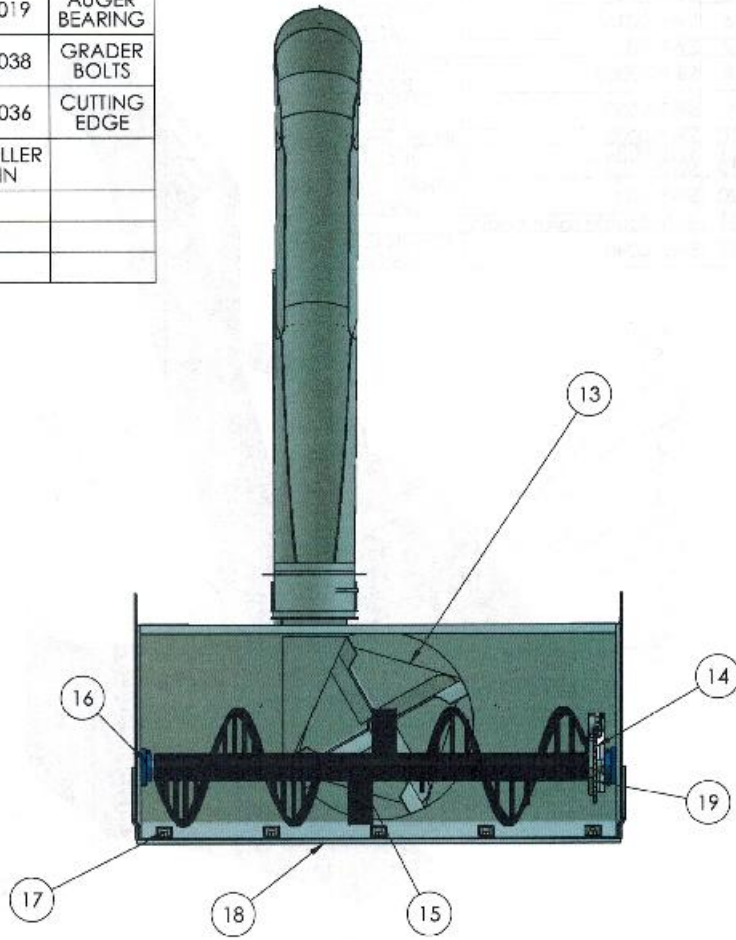

DRAWN BY:		DATE:		SMYTH WELDING & MACHINE SHOP LTD. #1-519-525-7212	
QTY	PART#	60-SH SMYTH HYDRAULIC SNOWBLOWER		REV.	
	3CA/2150 CWB				SCALE: 1:1

23	SWP-0010	12 VOLT ORBITAL ACTUATOR
24	SWP-0042	12 VOLT ACTUATOR

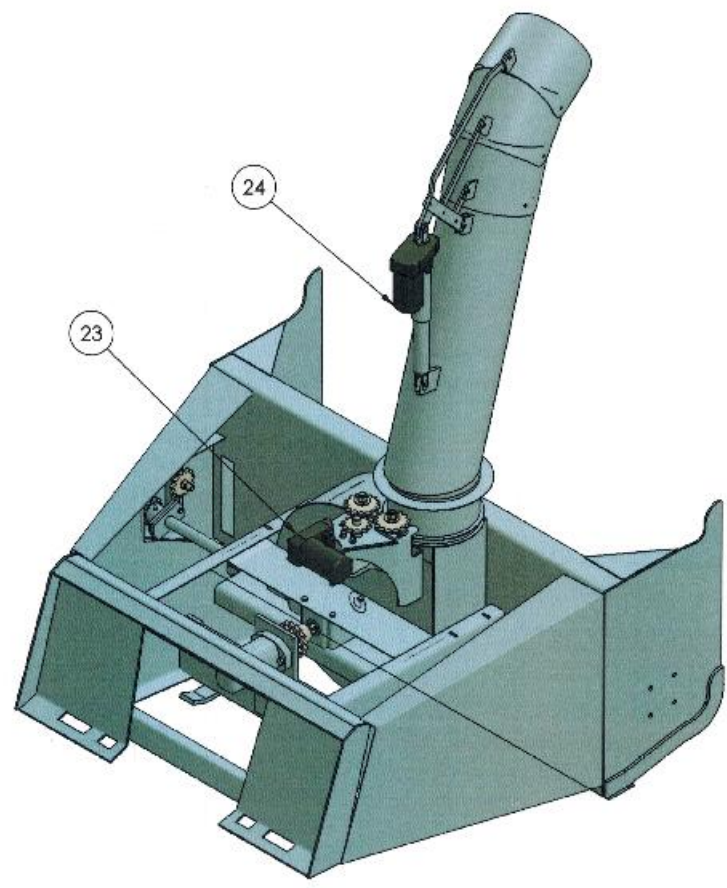

DATE		SMYTH WELDING & MACHINE SHOP LTD. #1-519-329-7272	
QTY	PARTS	SMYTH HYDRAULIC SNOWBLOWERS	REV.
	SCA. 5:163 (1x1)		DRG 1 OF 1

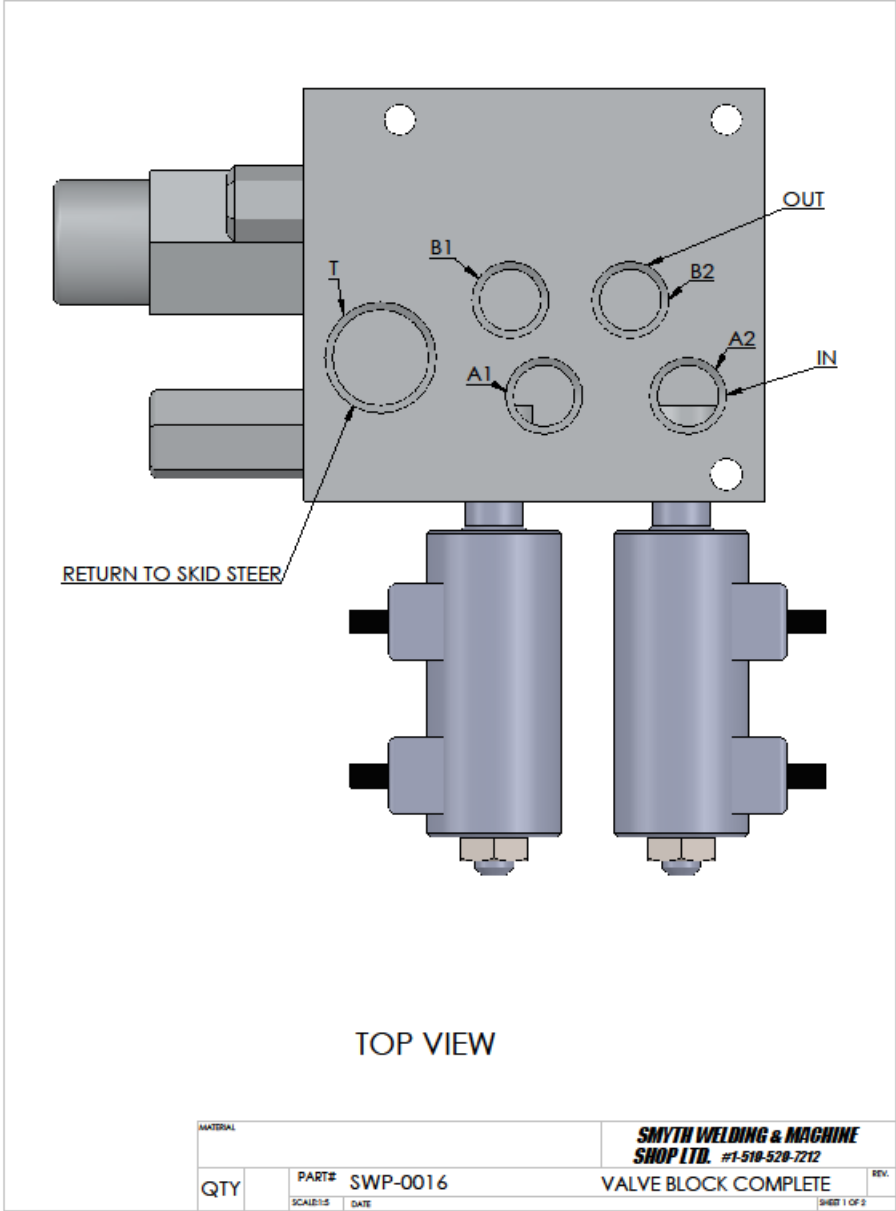

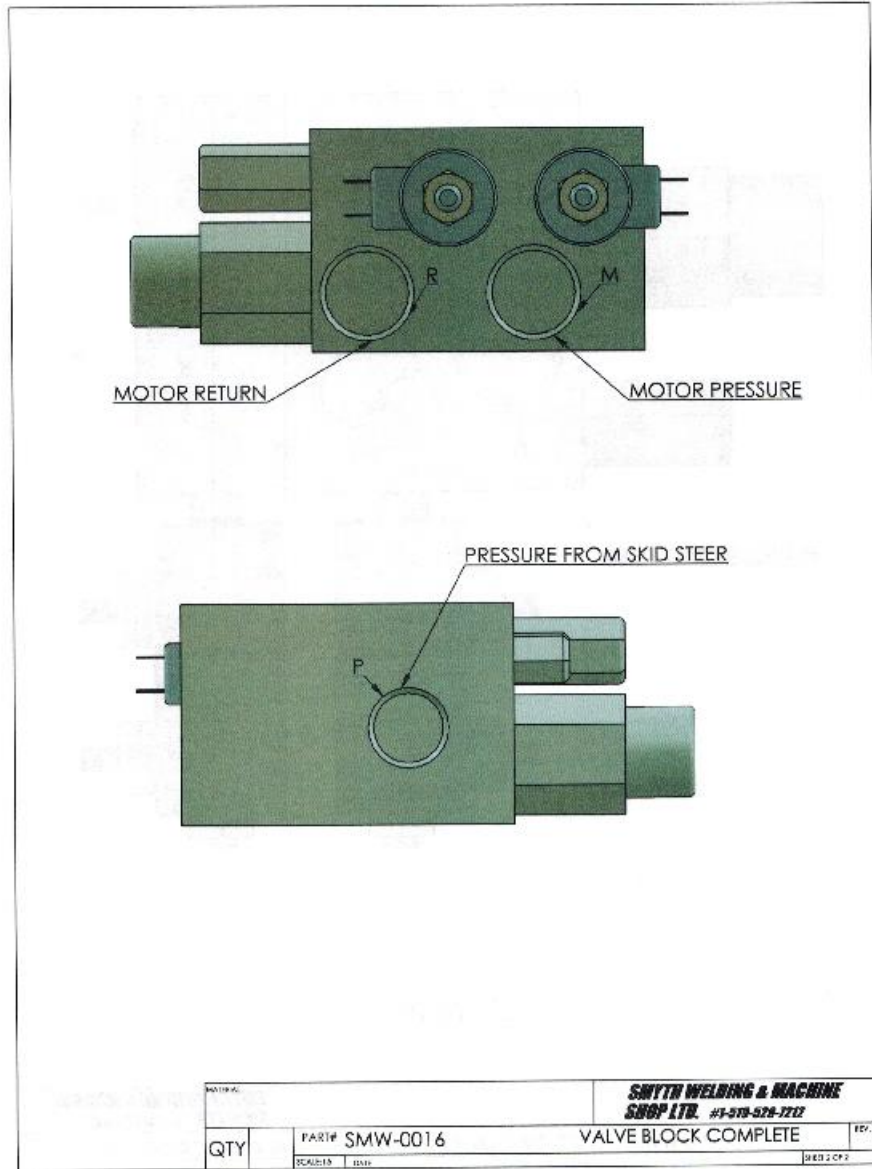

NOTES:		SMITH WELDING & MACHINE SHOP LTD. #1-878-528-7212	
QTY	PART# SMW-0016	VALVE BLOCK COMPLETE	REV.
SCALE: 1:1	DATE:	DATE:	DATE:

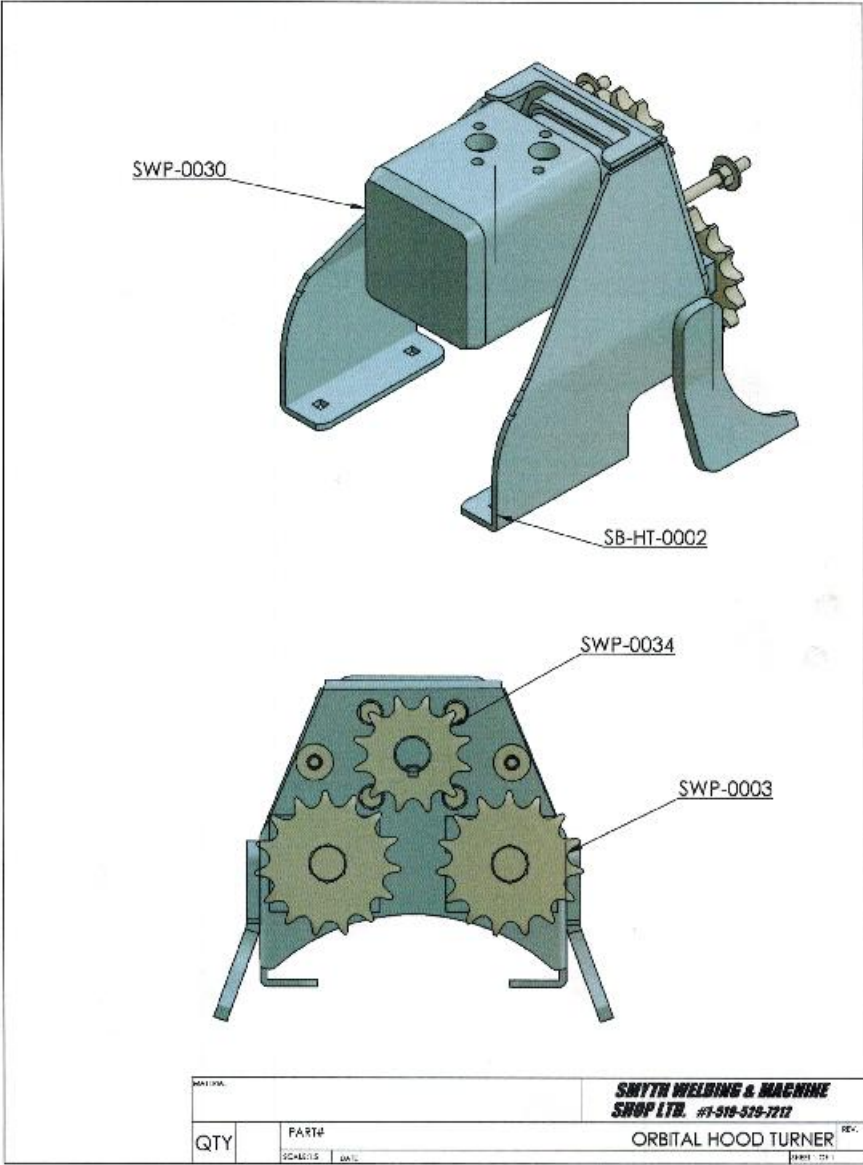

Manual Rotator Assembly

Place the crank assembly into the tube receiver on top of the fan housing and tighten the set bolt.

Standing on the hitch side of the snowblower, facing the auger, turn the hood opening to the 9:00 position.

Take one end of the cable and slide it through the cable clamp welded at the base of the hood opening, and into the cable clamp welded at the upper end of the crank assembly, then tighten both clamps.

Turn the crank in a clockwise rotation until the opening of the hood reaches the 3:00 position.

Put the remaining length of the cable through the cable clamp located at the lower end of the crank assembly and tighten.

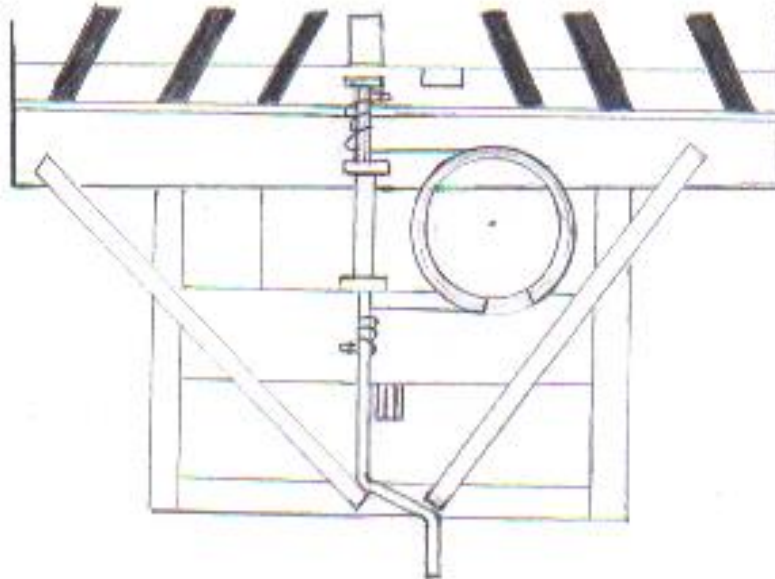

Hydraulic Rotator Assembly

With the hydraulic hood turner assembly firmly bolted in place, route the cable around the hood and attach each end of the cable to the corners of the “D” ring as shown.

With the hood opening pointing directly over the auger, position the tubing in the “D” ring so it points at the center of the hood base, then tighten all clamps.

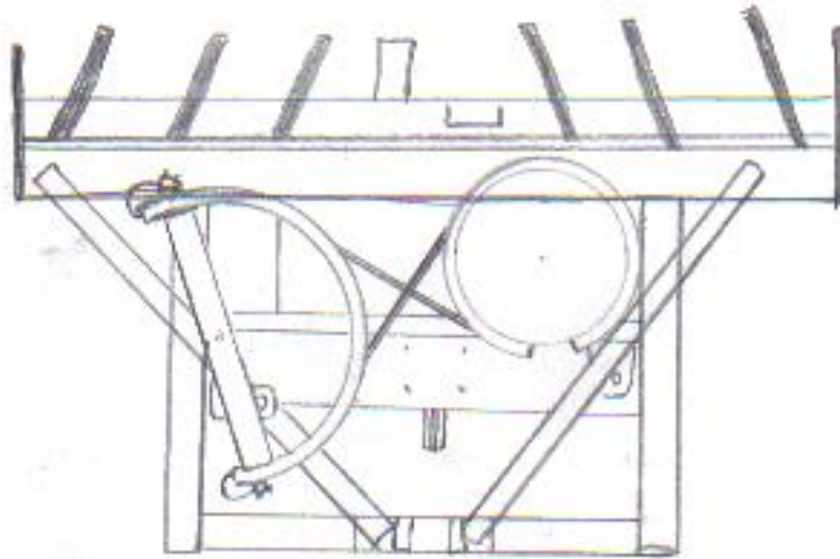

PTO GREASE FITTINGS

****Stop the tractor engine and lubricate the suggested points at the recommended intervals. Grease after periods of inactivity.**

16 hours

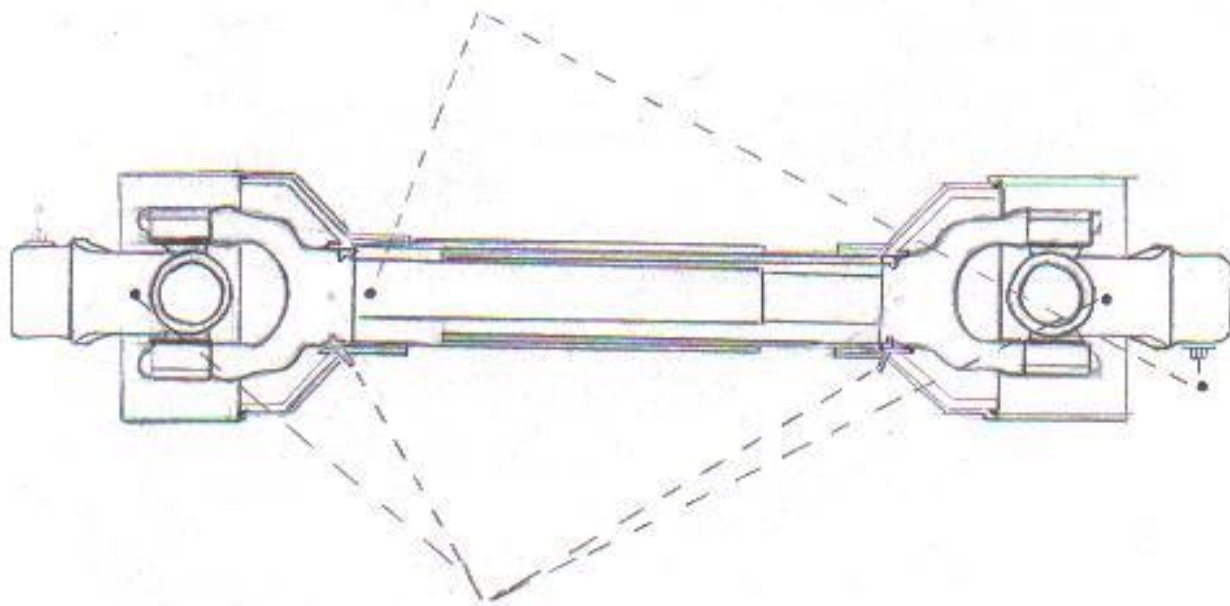

8 hours

TROUBLESHOOTING

Item	Avoldable Damages	Possible Causes	Corrective Actions
QUICK-DISCONNECT YOKE	-quick disconnect pin tight or completely seized	-quick-disconnect pin dirty (insufficient maintenance)	-clean, oil and follow service instructions
	-quick-disconnect pin damaged (broken or bent)	-quick-disconnect pin defective(forced engagement, incorrect handling)	-replace quick-disconnect pin
	-quick-disconnect pin damaged in the locking portion	-excessive shaft length	-shorten shaft length(cut both telescopic tubes as well as shields and remove burrs)
		-axial loads too high	-replace disconnect pin
			-clean and grease telescopic tubes, and replace both tubes, if necessary
			-replace quick-disconnect pin
**NOTE- Quick-dlscnect plns must be cleaned and greased every 16 working hours			

YOKE	-yoke ears deformation	-excessive shaft length	-shorten shaft length(cut both telescopic tubes as well as shields and remove burrs) -replace defective yokes
		-axial loads too high	-clean and grease telescopic tubes, and replace both tubes, if necessary -replace defective yokes
		-excessive working angle and torque	-verify compatibility between shaft & working conditions(torque vs. angle)
			-disengage tractor PTO during cornering or when lifting or lowering the implement
			-change to a larger PTO size
			-replace defective yokes
	-yoke ears distorted	-overload caused by high starting and peak torques	-engage PTO more carefully
			-use appropriate safety device
			-replace defective yokes

	-yoke ears worn or pounded	-excessive working angle	-avoid excessive working angle
			-disengage tractor PTO during cornering
			-replace defective yokes
CROSS KIT	-cross arms broken	-extreme torque peak or shock load	-use appropriate safety device
			-change to a larger PTO size
		-axial loads too high	-shorten PTO shaft
			-replace defective cross bearings
	-bearing caps turning in their cross journal	-excessive continuous torque and/or excessive working angle	-verify compatibility between shaft and working conditions
	-overheated bearing caps	-inadequate greasing	-carefully follow greasing instructions
			-replace defective cross bearings
	-accelerated wear of cross kit	-excessive continuous torque and/or excessive working angle	-verify compatibility between shaft and working conditions
		-inadequate greasing	-carefully follow greasing instructions
			-replace defective cross bearings
NOTE: CROSS BEARINGS MUST BE GREASED EVERY 8 WORKING HOURS			
TELESCOPIC TUBE	-telescopic tubes failure or twisting	-extreme torque peak or shock load	-use appropriate safety device
			-change to a larger PTO size
		-short tube engagement	-replace the PTO drive shaft with one having adequate length
			-replace defective tubes
	-accelerated wear telescopic tubes	-extreme load when sliding	-change to a PTO drive shaft with rilsan coated inner tube
		-short tube engagement	-replace the PTO drive shaft with one having adequate length
		-inadequate greasing	-carefully follow greasing instructions
		-contaminants(sand, etc.)	-replace defective tubes
NOTE: TELESCOPIC TUBES MUST BE CLEANED AND GREASED EVERY 16 WORKING HOURS			
SHIELD	-excessive wear of shield bearings	-insufficient lubrication	-follow lubrication instructions
		-incorrect chain mounting	-mount chain to allow maximum angularity
		-shield interfering with implement	-avoid contact of the shields with fixed parts of the machine or tractor
	-chain moving or failure	-shield interfering with implement	-avoid contact of the shields with fixed parts of the machine or tractor

		-incorrect chain mounting	-mount chain to allow maximum angularity
			-replace defective parts
	-guard cone damaged	-guard cone in contact with components on the tractor and/or implement	-eliminate interference between guard cones and any part on the tractor and/or implement
			-replace damaged guard cones
	-guard tubes damaged(deformed and split at one end)	-guards in contact with components on the tractor and/or implement	-eliminate interference between guard cones and any part on the tractor and/or implement
			-replace damaged tubes
		-guard tubes overlap too short or no overlap at all with extended PTO drive shaft	-adjust guard tubes length with longer tubes
NOTE: SHIELD BEARING MUST BE GREASED EVERY 8 WORKING HOURS			

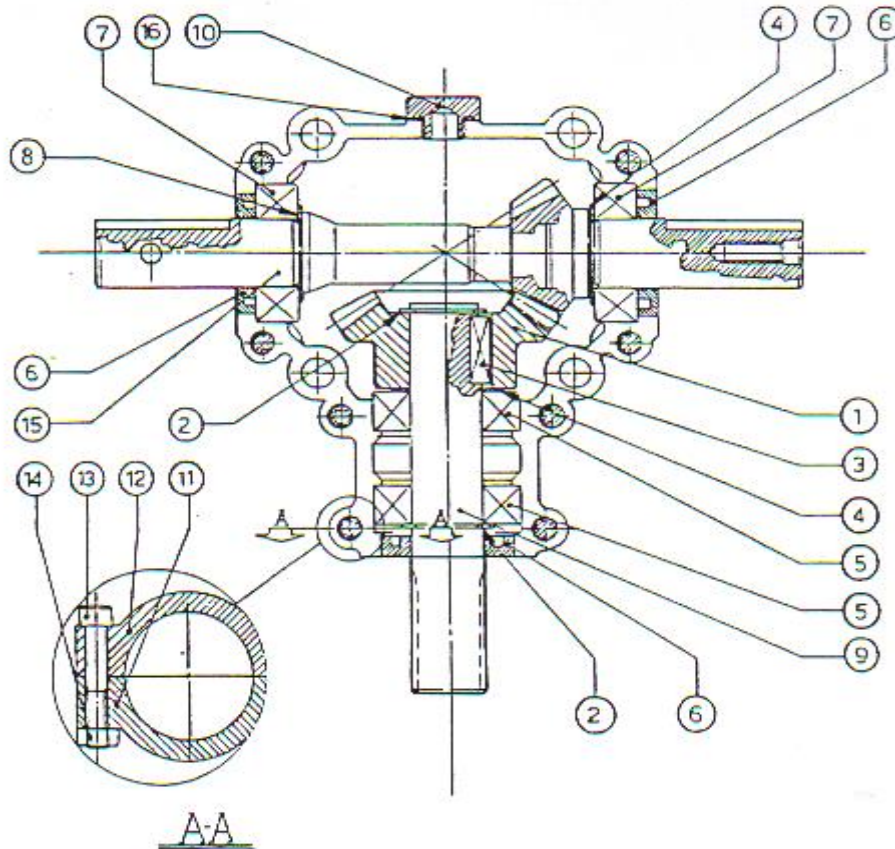

**L-25A Gearbox
(for 48", 54" & 60LS)**

Pos.	Drawg. Number	Description	Quantity
1.	0.124.6005.00	Crown Wheel Z24 M3.25	1
2.	8.5.1.00004	Snap Ring 25 Uni7435	2
3.	8.4.1.00015	Parallel Key A 8x7x25	1
4.	0.100.7507.00	Shim 25.6x0.7	2
5.	8.0.1.00598	Bearing 6205	2
6.	8.7.3.00257	Oil Seal 25x47x7	3
7.	0.124.7103.00	Bearing	2
8.	0.100.7506.00	Shim 25.6x0.6	2
9.	0.124.2429.00	Shaft 1"	1
10.	0.124.2429.00	Plug 3/8" gas	1
11.	1.124.0302.00	Casing A	1
12.	1.124.303.00	Casing A	1
13.	8.1.2.00248	Bolt M8x45 8,8	8
14.	8.2.1.00382	Hex Nut M8	8
15.	0.124.6258.00	Pinion Shaft Z16 M3.25	1
16.	8.7.6.00191	O-Ring OR-3062	1
500.	0.278.7812.00		

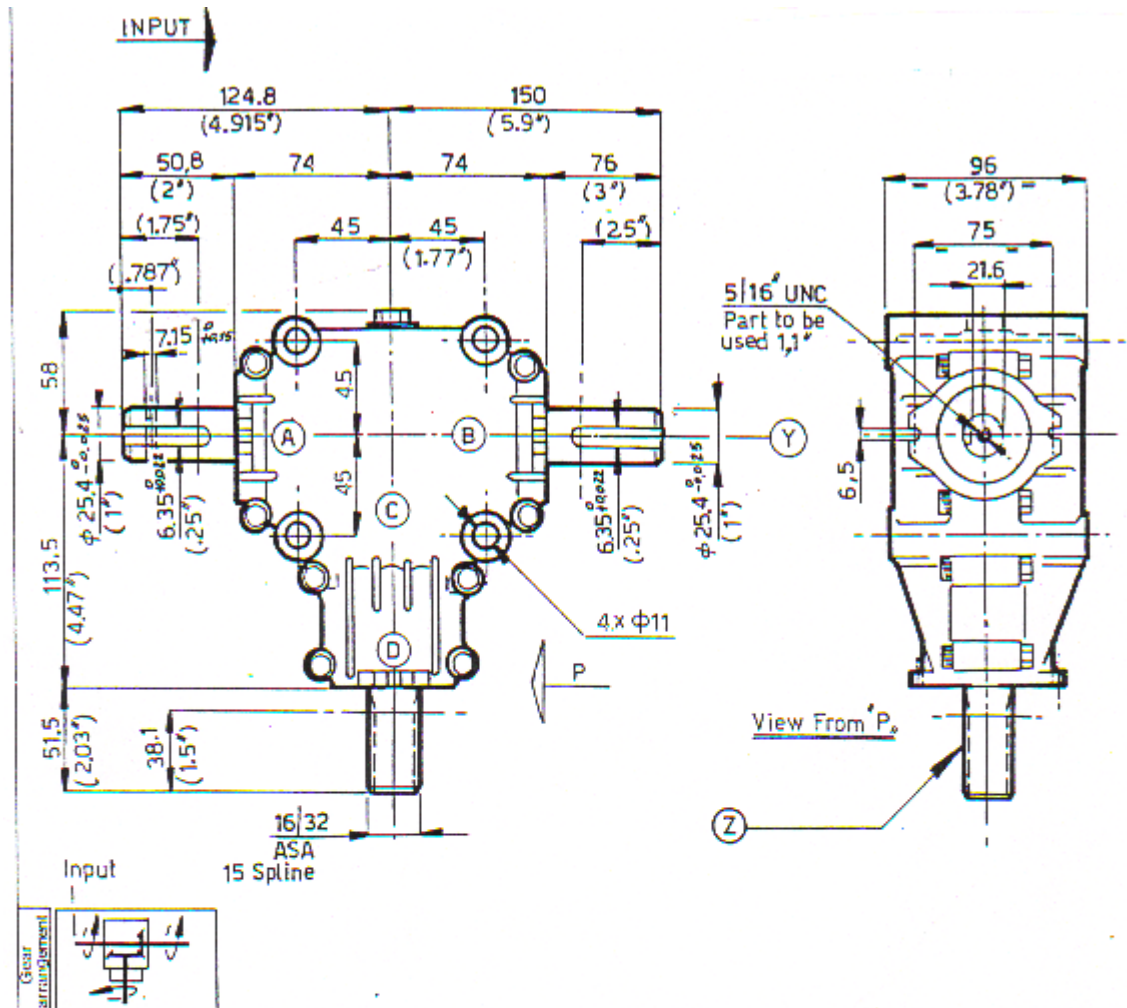

REDUCTION GEAR UNITS	Ratio		Rated input		Rated input power		Rated output torque	Weight	Lubricant					
			r.p.m.	HP	kW	da Nm	Kg	Oil <input checked="" type="checkbox"/>	Grease <input type="checkbox"/>					
	1.5:1		540	11	8	21	4.2	SAE.90EP	Quantity Kg	0.4				
	Bevel couplings				Cylindrical couplings				Bearings					
	Helicoidal	Teeth number			Module	Helicoidal	Teeth number			Module	A	6205.SP		
	Straight	Z ₁	Z ₂	Z ₃	Z ₄	m	Helicoidal	Z ₁	Z ₂	Z ₃	Z ₄	m	B	6205.SP
	*	16	24			3.25							C	6205
													D	6205
													E	
	Components material										F			
	Casing	Shaft Z	Shaft Y	Bevel gear		Spur gear					G			
	SGALSI 2/ GO 5076	C40.UNI.5332	16CrNi4 UNI 5331	16CrNi4 UNI 5331							H			

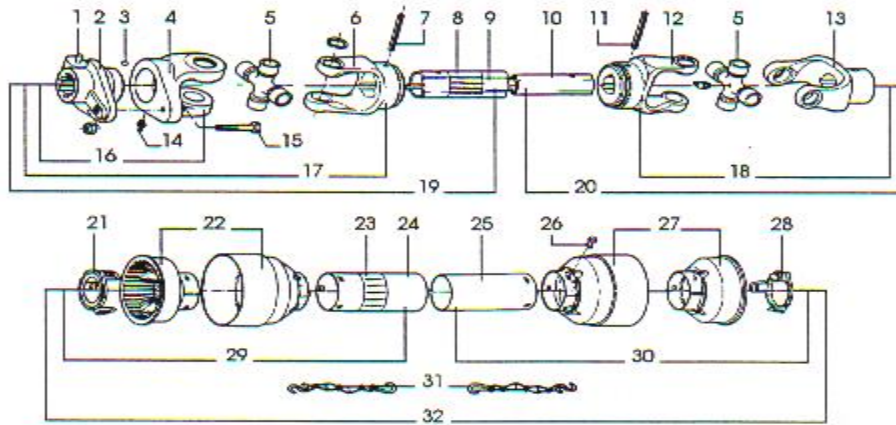

**T20 PTO
(for 48", 54" & 60LS)**

Pos.	Drawg. Number	Description	Quantity
1.	166.026.004	Push pin set 1 3/8"	1
2.	141.022.010	Hub B02	1
3.	190.000.024	Ball 7/32"	24
4.	151.012.005	Yoke for B02	1
5.	180.012.130	Cross journal set	2
6.	151.012.003	Outer yoke	1
7.	190.000.012	Roll pin for outer tube	1
8.	190.000.216	"DANGER" Label for outer tube	1
9.	152.120.289	Outer tube	1
10.	153.120.181	Inner tube	1
11.	190.000.011	Roll pin for inner tube	1
12.	151.012.002	Inner yoke	1
13.	151.012.304	Special yoke	1
14.	190.000.020	Grease nipple M8x1	1
15.	165.000.509	Bolt M6x40 cl.8.8 & nut	6
16.	143.220.001	Complete shear bolt B02	1
17.	121.022.526.10	U joint for outer tube	1
18.	121.022.570.10	U joint for inner tube	1
19.	123.220.647.10	Half female shaft	1
20.	123.220.343.10	Half male shaft	1
21.	180.012.007	Guard retaining collar for outer tube	1
22.	180.012.013	Cone for outer tube	1
23.	190.000.215	"DANGER" Label for outer shield tube	1
24.	156.111.143	Outer shield	1
25.	157.111.241	Inner shield	1
26.	190.000.019	Bolt	6
27.	180.012.012	Cone for inner tube	1
28.	180.012.006	Guard retaining collar for inner tube	1
29.	142.221.134	Half female shield	1
30.	142.221.231	Half male shield	1
31.	180.016.025	Safety chains	2
32.	142.220.252	Complete shield type P	1

Code 07.23102110 Description T200560PB02530

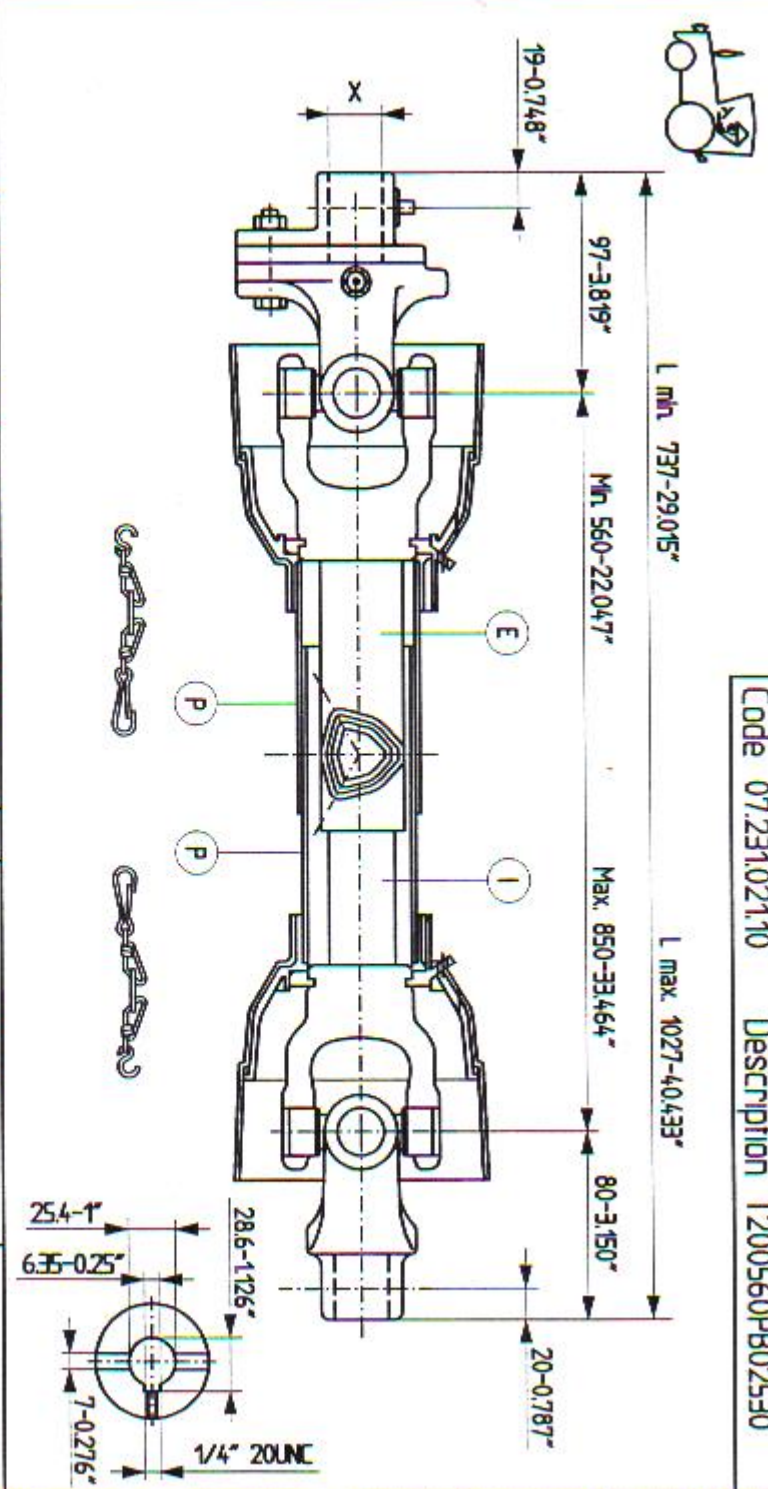

	SERIES	X	1 3/8" Z6 DIN 9611	B	90 daNm
	T 20	Y	/	F	/
Ref. code:		E	435-17.126"	R	/
		I	450-17.716"	N	/
		P	370-14.567"		

Apply "ADMA" label in two languages code: 90.000.225
Date: 05-04-94

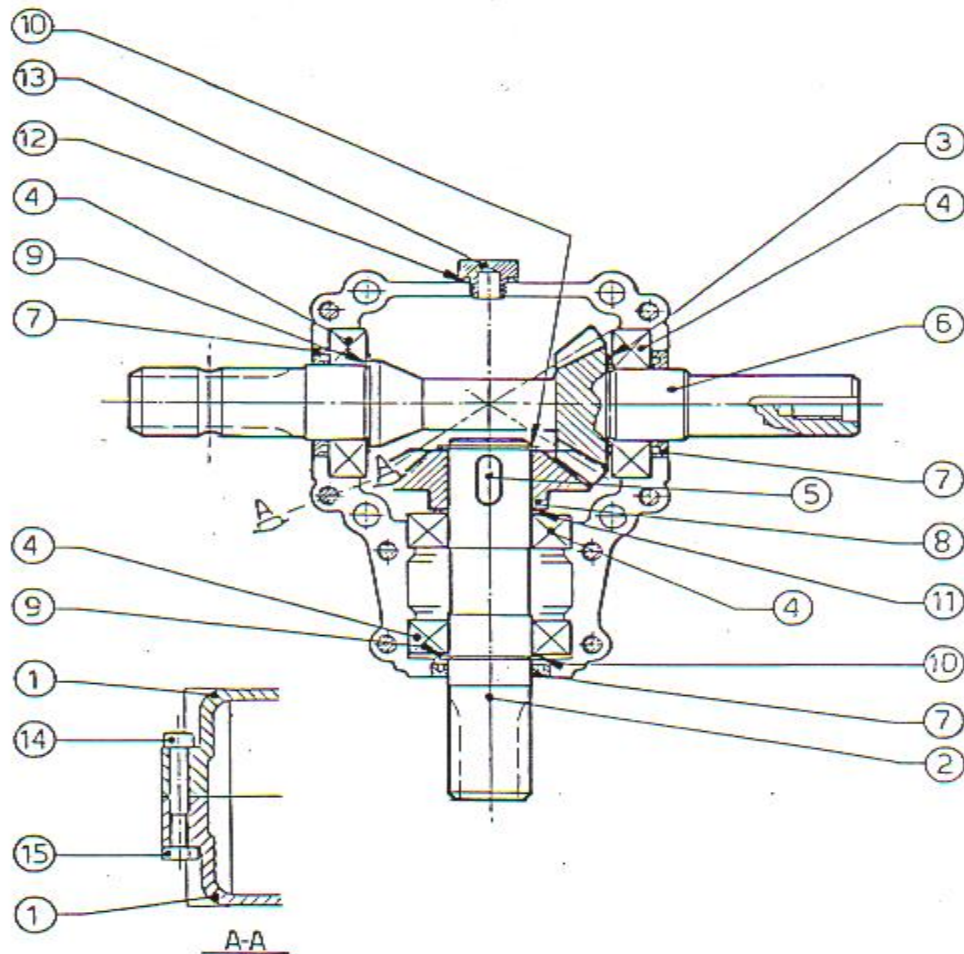

**T-281A Gearbox
(for 60", 72" & 78")**

Pos.	Drawg. Number	Description	Quantity
1.	1.281.0300.00	Casing	2
2.	0.281.2207.00	Shaft 1 1/4"	1
3.	0.259.7500.00	Shim 48.0	1
4.	8.0.1.00025	Bearing 6207	4
5.	8.4.1.00057	Parallel Key A 10x8x30	1
6.	0.281.6200.00	Pinion shaft Z13 M5	1
7.	8.7.3.00028	Oil Seal 35x52x7	3
8.	0.259.6000.00	Crown wheel Z19 M5	1
9.	0.259.7505.00	Shim 35.3x0.5	2
10.	8.5.1.00005	Snap ring 35 Uni7435	2
11.	0.259.7506.00	Shim 35.3x0.6	1
12.	8.7.6.00191	O-Ring OR-3062	1
13.	0.281.7100.00	Plug	1
14.	8.1.2.01174	Bolt M8x55 8,8	8
15.	8.2.1.00382	Hex nut M8 8	8

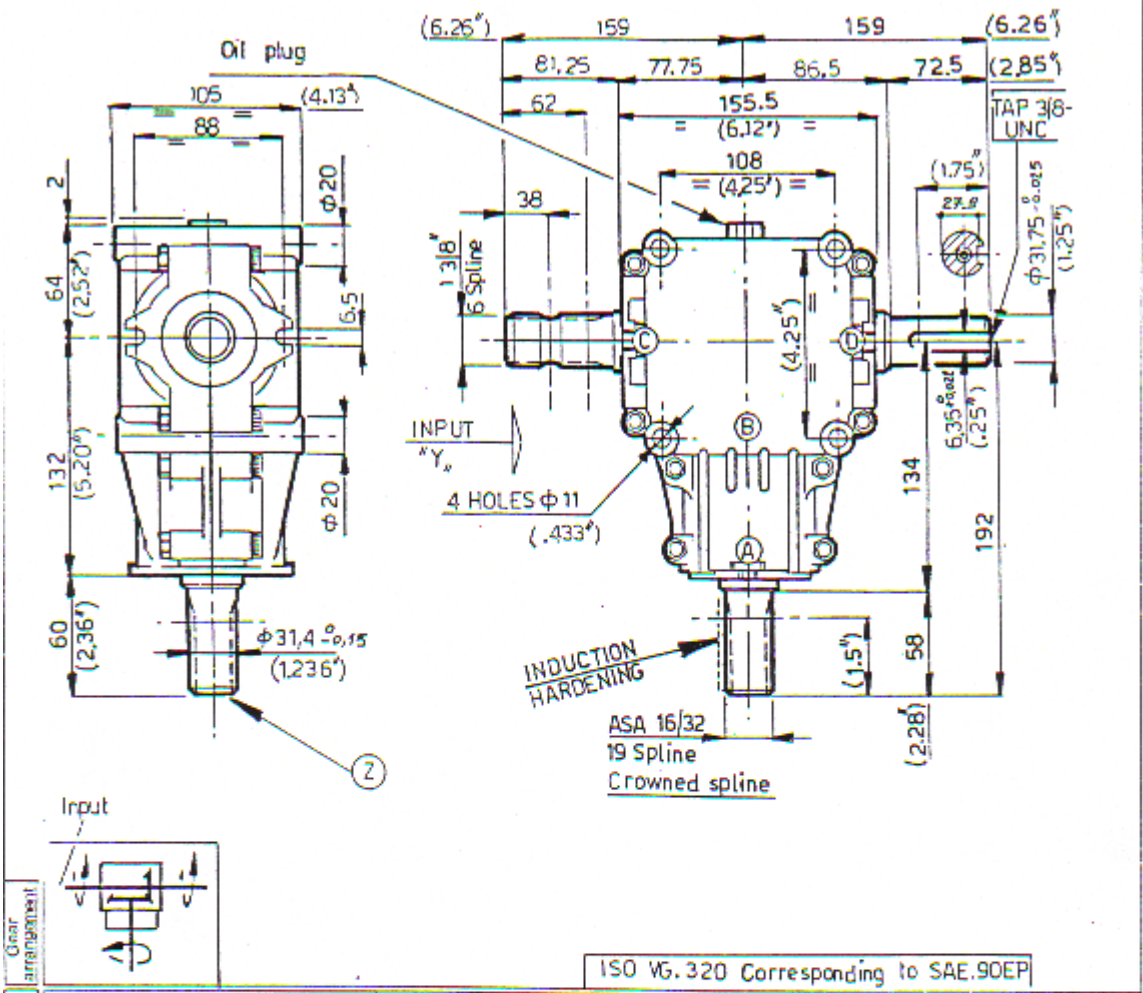

ISO VG.320 Corresponding to SAE.90EP

Ratio		Rated input		Rated input power		Rated output torque		Weight		Lubricant												
		r.p.m.	HP	KW	da Nm	Kg	Oil <input checked="" type="checkbox"/>	Grease <input type="checkbox"/>	Type	Quantity Kg												
1,46:1		540	20	14,7	37	7	ISO VG.320	-														
Bevel couplings						Cylindrical couplings						Bearings										
Helicoidal	Straight	Teeth number				Module	Helicoidal	Straight	Teeth number				Module	A	B	C	D	E	F	G	H	
		Z ₁	Z ₂	Z ₃	Z ₄				m	Z ₁	Z ₂	Z ₃										Z ₄
*		13	19			5																
Components material																						
Casing		Shaft Y		Shaft Z		Bevel gear						Spur gear										
SGAL S1 2/GD 5076		AISI (3115)		AISI (1040)		AISI 3115																

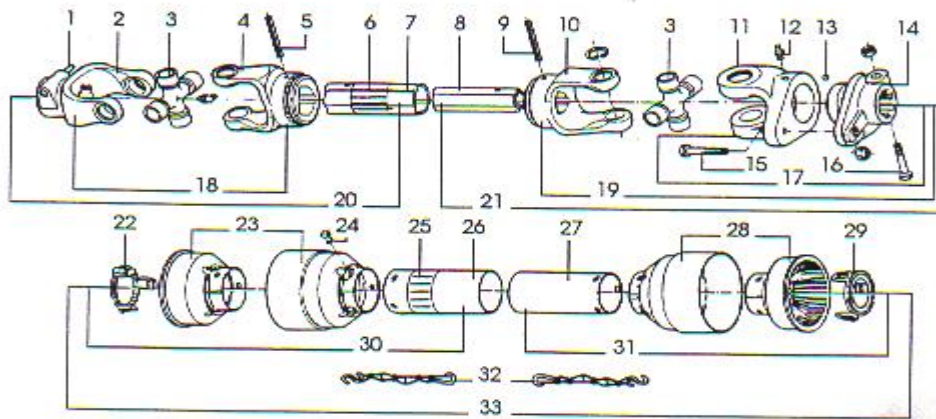

**T40 PTO
(for 60", 72" & 78")**

Pos.	Drawg. Number	Description	Quantity
1.	166.026.009	Push pin set 1 3/8" old type	1
2.	141.024.271	Push pin yoke 112 old type	1
3.	180.014.130	Cross journal set	2
4.	151.014.006	Outer yoke	1
5.	190.000.014	Roll pin for outer tube	1
6.	190.000.216	"DANGER" Label for outer tube	1
7.	152.140.280	Outer tube	1
8.	153.140.188	Inner tube	1
9.	190.000.012	Roll pin for inner tube	1
10.	151.014.007	Inner yoke	1
11.	151.014.012	Yoke for B02	1
12.	190.000.020	Grease nipple M8x1	1
13.	190.000.022	Ball 1/4"	23
14.	141.024.270	Hub B02 with interfering clamp bolt	1
15.	165.000.505	Bolt M8x50 cl.8.8 & nut	6
16.	165.000.525	Bolt M12x1,25x70 cl.8.8 & nut	2
17.	143.240.008	Complete shear bolt B02	1
18.	121.024.609.10	U joint for outer tube	1
19.	121.024.610.10	U joint for inner tube	1
20.	123.240.673.10	Half female shaft with shielding	1
21.	123.240.386.10	Half male shaft with shielding	1
22.	180.013.012	Guard retaining collar for outer tube	1
23.	180.013.016	Cone for outer tube	1
24.	190.000.019	Bolt	6
25.	190.000.215	"DANGER" Label for outer shield tube	1
26.	156.141.554	Outer shield	1
27.	157.141.279	Inner shield	1
28.	180.013.015	Cone for inner tube	1
29.	180.013.011	Guard retaining collar for inner tube	1
30.	142.241.153	Half female shield	1
31.	142.241.253	Half male shield	1
32.	180.016.025	Safety chains	2
33.	142.240.293	Complete shield type P	1



Code 07.431.047.10 Description T400560P112B02

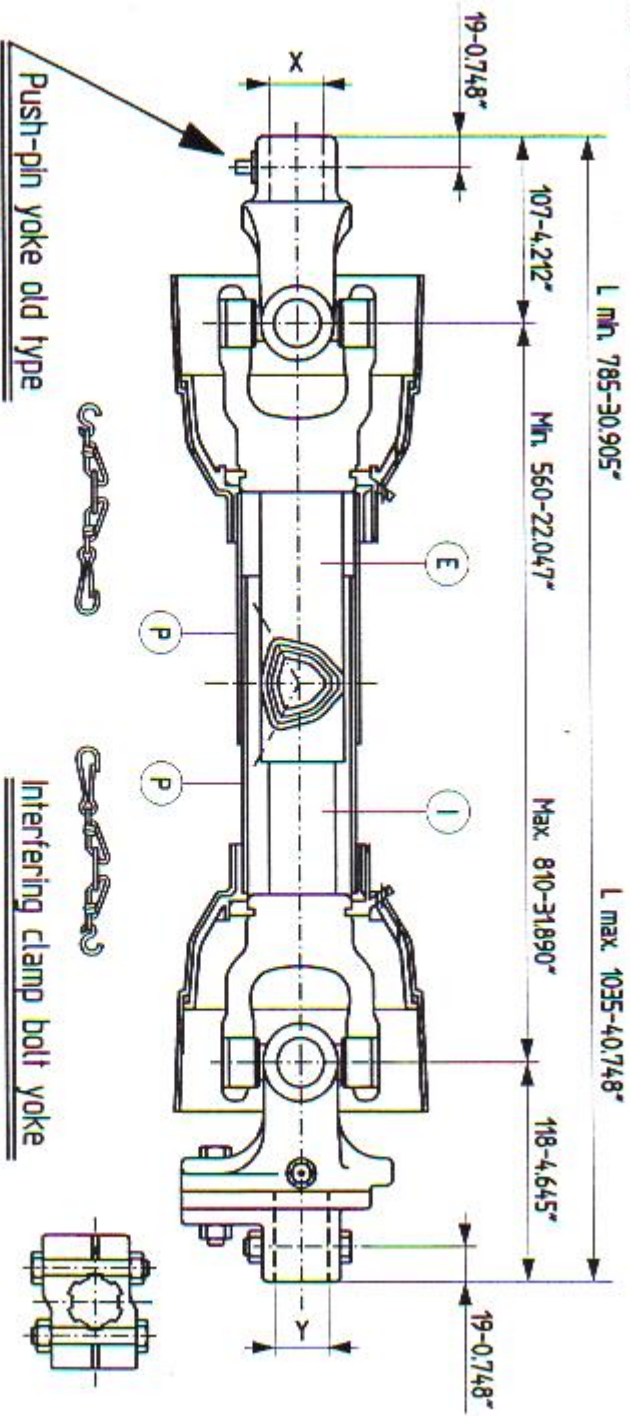

EG

SERIES
T40

X	1 3/8" Z6 DIN 9611
Y	1 3/8" Z6 DIN 9611
E	415-16.338"
I	430-16.930"
P	345-13.582"

170 daNm

Ref. code

Apply "ADMA" label in two languages code 90.000.225

B	
F	
R	
N	

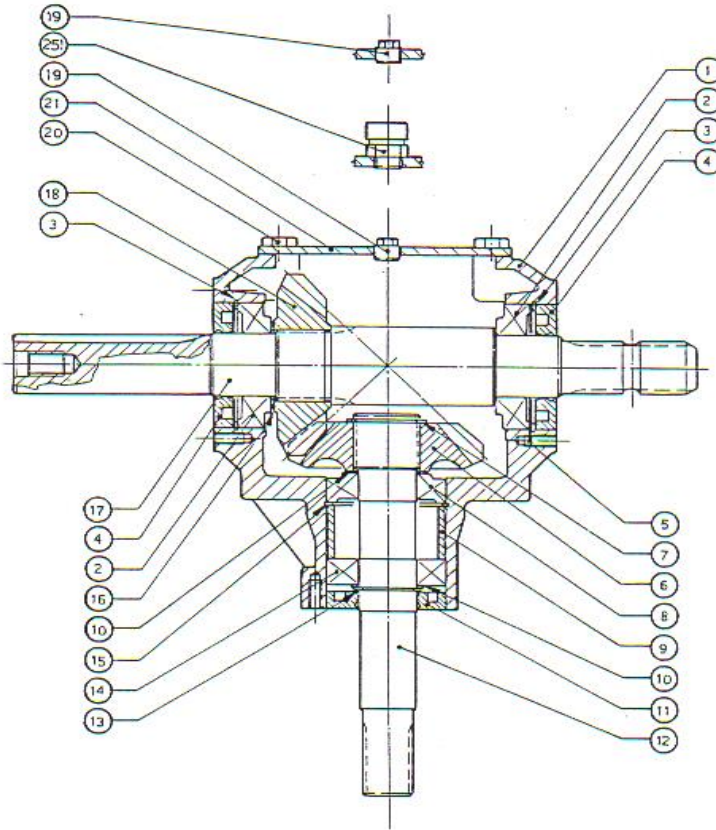

**T-27D Gearbox
(for 84", & 96")**

Pos.	Drawg. Number	Description	Quantity
1.	0.267.0301.00	Casing	1
2.	8.0.9.00024	Bearing 30208	2
3.	8.5.2.00030	Snap ring 80 Uni7437	2
4.	8.7.1.00748	Double lip seal 40x8x12	2
5.	0.110.7500.00	Shim 79,7	1
6.	0.267.5000.00	Gear Z18 M6.15	1
7.	8.5.1.00029	Snap ring 40 Uni7435	1
8.	8.0.9.00026	Bearing 30207	1
9.	0.267.7100.00	Spacer	1
10.	0.259.7500.00	Shim 48.0	2
11.	8.7.1.00152	Double lip seal 35x72x10	1
12.	0.267.2000.00	Shaft 16/32" Z19	1
13.	8.5.1.00005	Snap ring 35 Uni7435	1
14.	8.0.1.00025	Bearing 6207	1
15.	8.5.2.00131	Snap ring 72 Uni7437	1
16.	0.244.7500.00	Shim 51.5	1
17.	0.267.4218.00	Shaft	1
18.	0.132.5002.00	Gear Z18 M6.15	1
19.	8.6.5.00006	Plug 3/8" gas	2
20.	8.1.1.01031	Bolt M10x14 8,8	4
21.	0.267.1300.00	Cover	1
251	8.6.7.00161	Oil filler plug 3/8G	1
500	0.124.7101.00	Plate	1
500	0.278.7813.00		1
500	0.278.7819.00		1
500	8.6.0.01684		1

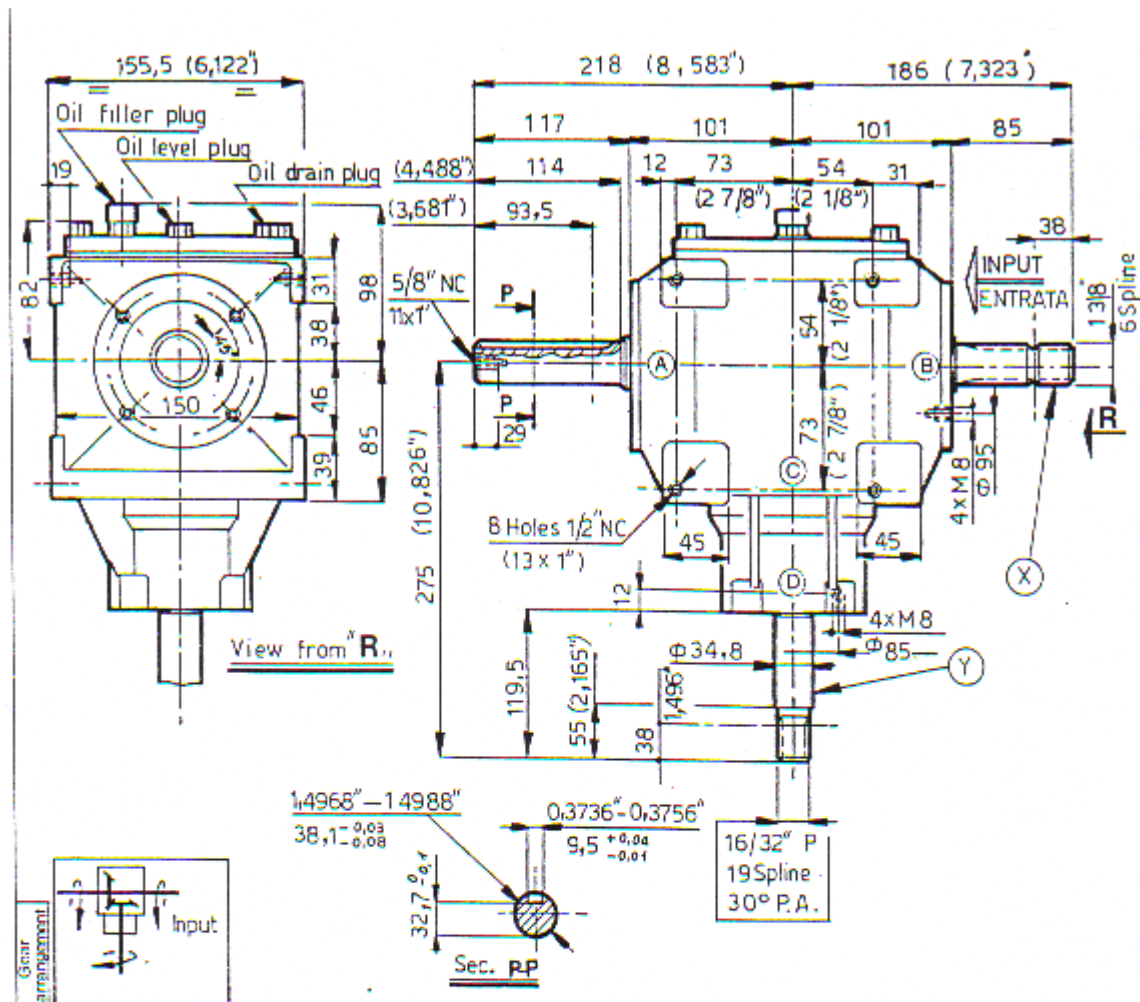

Ratio	Rated input r.p.m.	Rated input power		Rated output torque da Nm	Weight Kg	Lubricant									
		HP	kW			Oil Type	Grease Quantity Kg								
1:1	540	5,5	40,5	69	23	SAE 90EP	1,2								
Bevel couplings				Cylindrical couplings				Bearings							
Helicoidal	Straight	Teeth number				Module	Helicoidal	Straight	Teeth number				Module	A	30208
		Z ₁	Z ₂	Z ₃	Z ₄				m	Z ₁	Z ₂	Z ₃			
*		18	18			6,15								B	30208
														C	30207
														D	6207
														E	
Components material														F	
														G	
Casing		Shaft Y		Shaft X		Bevel gear		Sour gear				H			
G25 UNI 5007		16 CrNi 4 UNI 5331		20Mn Cr 5		20CrNi 4						H			

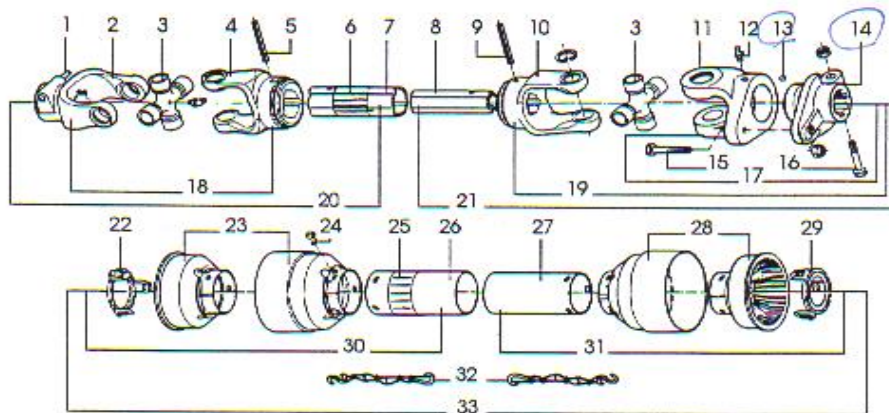

**T50 PTO
(for 84" & 90")**

Pos.	Drawg. Number	Description	Quantity
1.	166.026.009	Push pin set 1 3/8" old type	1
2.	141.025.230	Push pin yoke 112 old type	1
3.	180.015.130	Cross journal set	2
4.	151.015.011	Outer yoke	1
5.	190.000.015	Roll pin for outer tube	1
6.	190.000.216	"DANGER" Label for outer tube	1
7.	152.150.209	Outer tube	1
8.	153.150.109	Inner tube	1
9.	190.000.014	Roll pin for inner tube	1
10.	151.015.012	Inner yoke	1
11.	151.015.024	Yoke for B02	1
12.	190.000.020	Grease nipple M8x1	1
13.	190.000.022	Ball 1/4"	23
14.	141.025.260	Hub B02 with interfering clamp bolt	1
15.	165.000.511	Bolt M10x55 cl.8.8 & nut	6
16.	165.000.525	Bolt M12x1,25x70 cl.8.8 & nut	2
17.	143.250.016	Complete shear bolt B02	1
18.	121.025.582.10	U joint for outer tube	1
19.	121.025.583.10	U joint for inner tube	1
20.	123.250.674.10	Half female shaft with shielding	1
21.	123.250.359.10	Half male shaft with shielding	1
22.	180.015.009	Guard retaining collar for outer tube	1
23.	180.016.023	Cone for outer tube	1
24.	190.000.019	Bolt	6
25.	190.000.215	"DANGER" Label for outer shield tube	1
26.	156.151.109	Outer shield	1
27.	157.151.209	Inner shield	1
28.	180.016.022	Cone for inner tube	1
29.	180.015.008	Guard retaining collar for inner tube	1
30.	142.251.151	Half female shield	1
31.	142.251.248	Half male shield	1
32.	180.016.025	Safety chains	2
33.	142.250.285	Complete shield type P	1

Code 07.531037.10 Description T500710P112B02

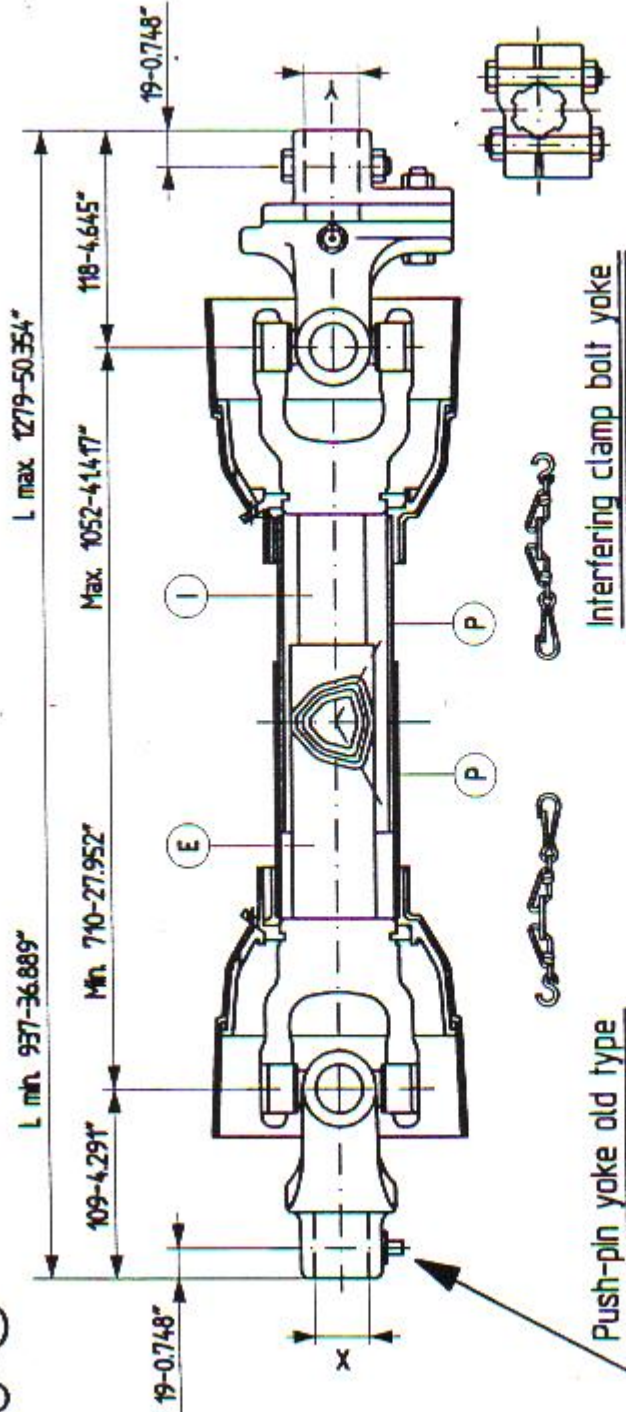

	SERIES	X	1 3/8" Z6 DIN 9611	B	210 daNm
	T50	Y	1 3/8" Z6 DIN 9611	F	/
Ref.code		E	560-22.047"	R	/
		I	575-22.637"	N	/
		P	485-19.094"		

Apply "ADMA" label in two languages code 90.000.225

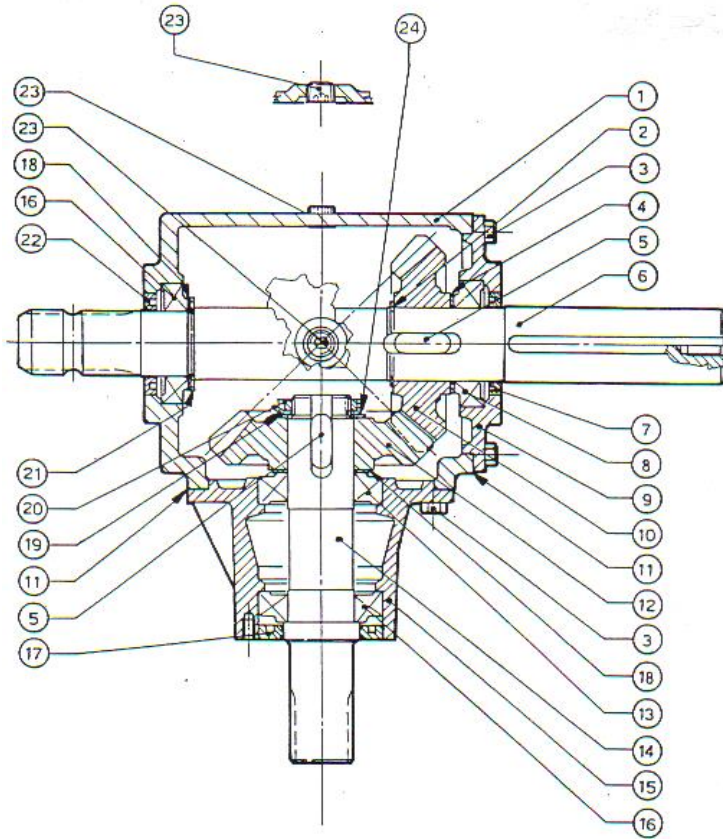

**T-279A Gearbox
(for 102" & 108")**

Pos.	Drawg. Number	Description	Quantity
1.	0.279.0300.00	Casing T4	1
2.	8.5.1.00533	Snap ring 50 Uni7435	1
3.	8.1.1.00501	Bolt M10x22 8,8	16
4.	0.712.7500.00	Shim 70.3	1
5.	8.4.1.00978	Parallel key B 14x9x40	2
6.	0.279.3010.00	Shaft	1
7.	8.7.1.01097	Oil seal 50x72x8	1
8.	8.0.9.00469	Bearing 30210	1
9.	0.279.1300.00	Cover	1
10.	0.279.6000.00	Gear Z21 M7,14	1
11.	0.248.7200.00	Gasket	2
12.	0.279.5000.00	Gear Z21 M7,14	1
13.	8.0.9.00125	Bearing 32209	1
14.	0.279.2000.00	Shaft 1 3/4" Z20	1
15.	0.279.1301.00	Extension AC	1
16.	8.0.9.00143	Bearing 30209	2
17.	8.7.3.01096	Oil seal 52x85x10	1
18.	0.252.7500.00	Shim 65.3	2
19.	8.3.8.00065	Spring washer x1, 25C40B0N	1
20.	8.2.5.00064	Locknut M40x1,5 H9	1
21.	0.252.7525.00	Shim 45.3x2.5	1
22.	8.7.1.00981	Double lip seal 45x72x8	1
23.	8.6.6.0021	Plug 3/8" Gas	4
24.	0.244.7510.00	Shim 40.3x1.0	1
500	0.124.7101.00	Plate	1
500	0.278.7813.00		2
500	0.278.7835.00		1

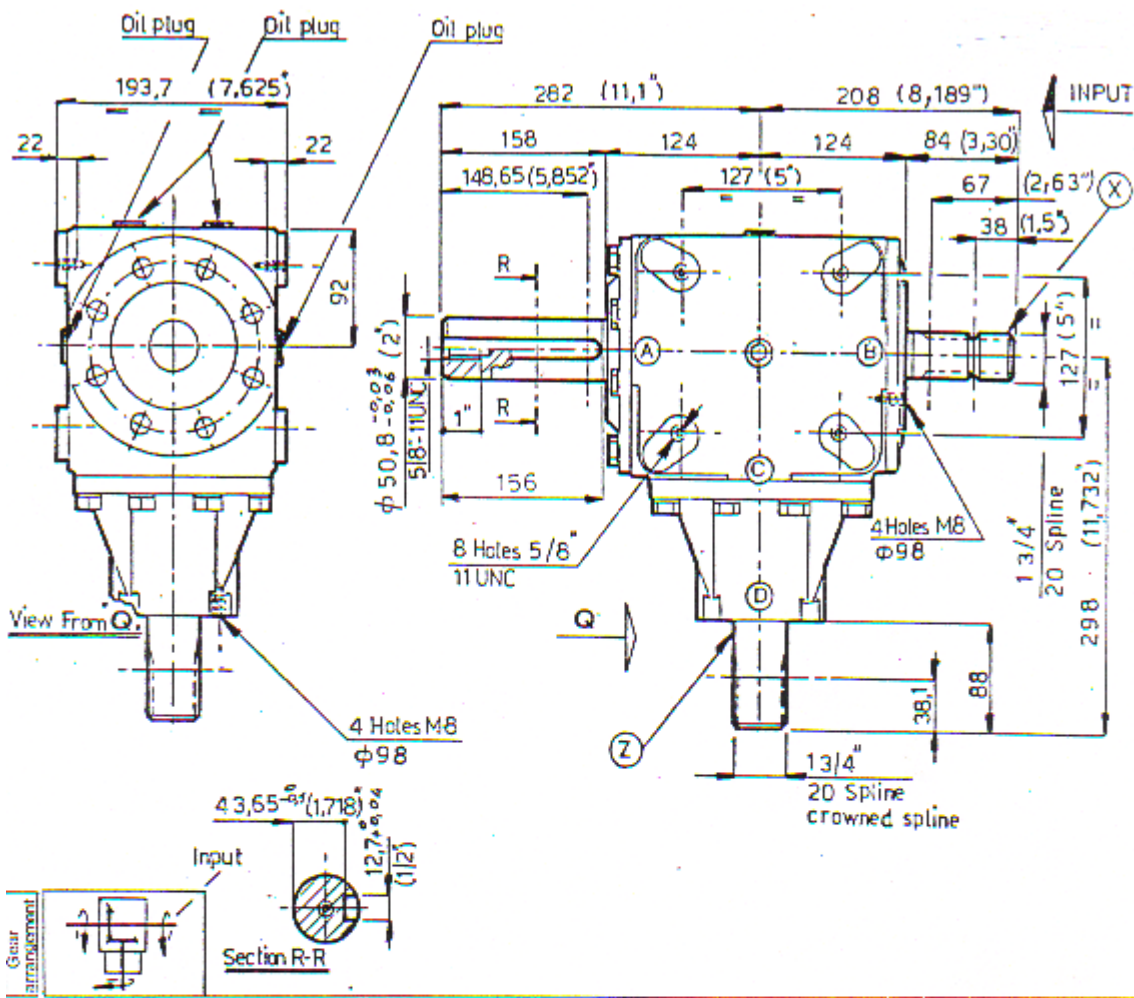

90° BEVEL GEARS	Ratio		Rated input		Rated input power		Rated output torque	Weight	Lubricant					
	i		r.p.m.		HP	kW	da Nm	Kg	Oil <input checked="" type="checkbox"/>	Grease <input type="checkbox"/>				
	1:1		540		100	73,5	126	37	SAE.90EP	Quantity Kg 2,5				
	Bevel couplings				Cylindrical couplings				Bearings					
	Helicoidal	Teeth number			Module	Helicoidal	Teeth number			Module	A	30210		
	Straight	Z ₁	Z ₂	Z ₃	Z ₄	m	Straight	Z ₁	Z ₂	Z ₃	Z ₄	m	B	30209
	*	21	21			7,14							C	32209
													D	30209
													E	
													F	
													G	
													H	
	Components material													
	Casing	Shaft X		Shaft Z		Bevel gear		Spur gear						
	G 25 UNI 5007	20 MnCr 5		C 40 bon. UNI 5332		16CrNi4 UNI 5331								

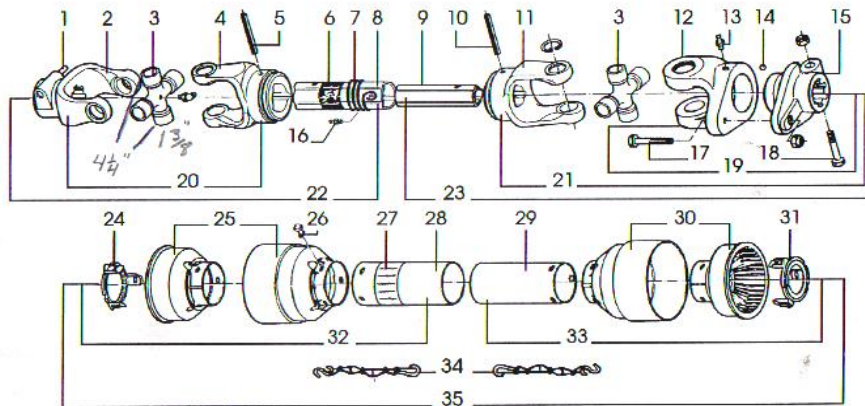

**T80 PTO
(for 102" & 108")**

Pos.	Drawg. Number	Description	Quantity
1.	166.026.009	Push pin set 1 3/8" old type	2
2.	141.028.161	Push pin yoke 112 old type	1
3.	180.018.130	Cross journal set	2
4.	151.018.133	Outer yoke	1
5.	190.000.243	Roll pin for outer tube	1
6.	190.000.216	"DANGER" Label for outer tube	1
7.	180.019.114	Shield support	1
8.	152.198.117	Outer tube	1
9.	159.190.025	Hardened inner tube	1
10.	190.000.271	Roll pin for inner tube	1
11.	151.018.134	Inner yoke	1
12.	151.018.023	Yoke for B05	1
13.	190.000.021	Grease nipple M10x1	1
14.	190.000.023	Ball 5/16"	24
15.	141.028.162	Hub B05 with interfering clamp bolt	1
16.	166.000.542	Grease nipple kit	1
17.	165.000.539	Bolt M12x65 cl.10.9 & nut	6
18.	165.000.584	Bolt M12x1,25x90 cl.8.8 & nut	2
19.	143.280.016	Complete shear bolt B05	1
20.	121.028.637.10	U joint for outer tube	1
21.	121.028.636.10	U joint for inner tube	1
22.	123.280.680.10	Half female shaft with shielding	1
23.	123.280.371.10	Half male shaft with shielding	1
24.	180.019.121	Guard retaining collar for outer tube	1
25.	180.019.123	Cone for outer tube	1
26.	190.000.019	Bolt	6
27.	190.000.215	"DANGER" Label for outer shield tube	1
28.	156.198.117	Outer shield	1
29.	157.198.117	Inner shield	1
30.	180.019.124	Cone for inner tube	1
31.	180.019.122	Guard retaining collar for inner tube	1
32.	142.281.146	Half female shield	1
33.	142.281.255	Half male shield	1
34.	180.016.025	Safety chains	2
35.	142.286.016	Complete shield type P	1

Code 07.831.124.10 Description T800660P112B05

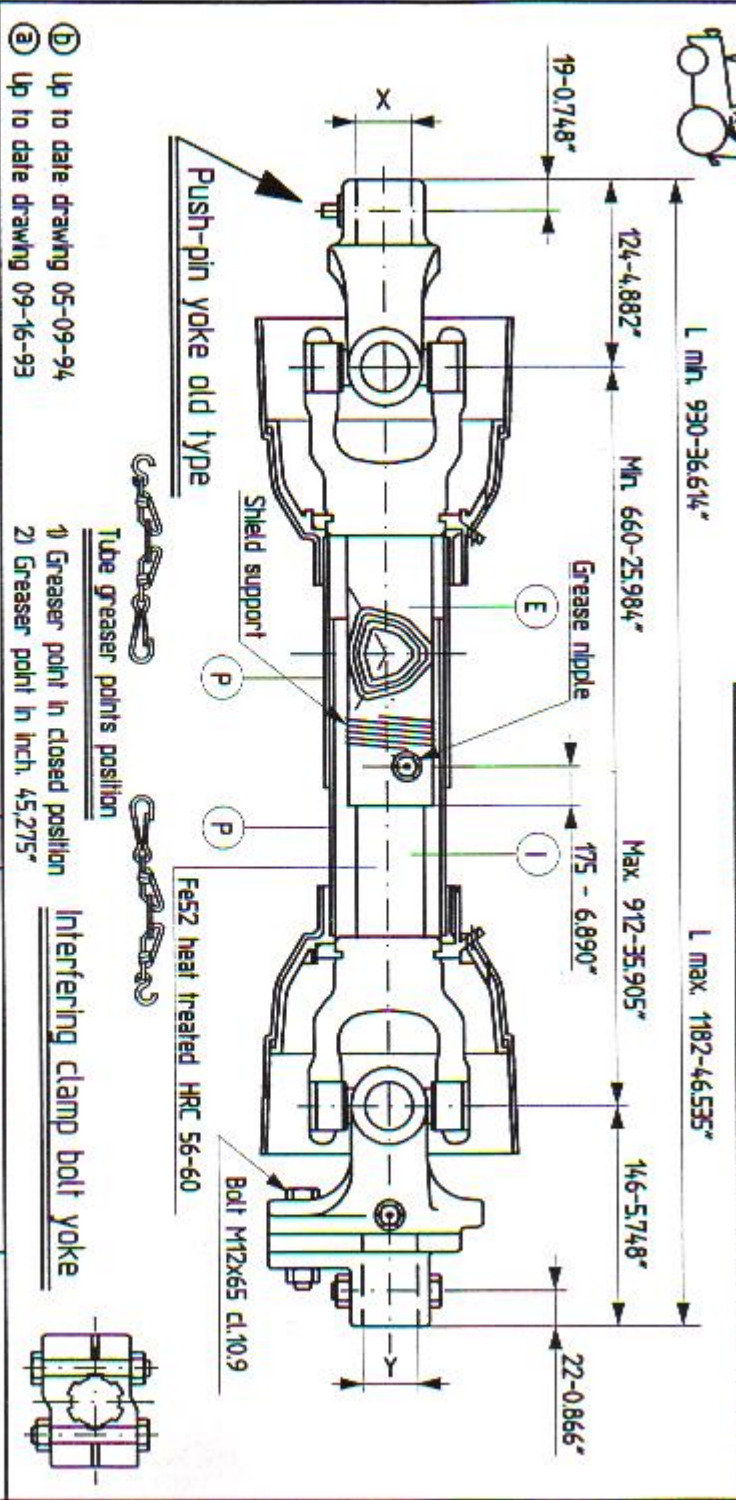

- Ⓛ Up to date drawing 05-09-94
- Ⓛ Up to date drawing 09-16-93

EG SERIES T80

Ref. code
Apply "ADMA" label in two languages code 90.000.225

X	1 3/8" Z6 DIN 9611	B	435 daNm Ⓛ
Y	1 3/4" Z20 DIN 9611	F	/
E	470-18,504"	R	/
I	485-19,094"	N	/
P	395-15,551"		

Instruction for snowblowers Chain box maintenance

**** This chain box has double functions.**

- 1. Reduce angles at both ends of PTO in working position by increasing the input shaft height of 8"**
- 2. Increase PTO capacity by increasing speed from 540 RPM to 1000 RPM.**

In order to obtain a longer life expectancy of this chain box which is constantly submitted to high shock loads, a minimum care is essential.

- A. PTO shear bolt**
Because the PTO is running at 1000 RPM instead of 540 RPM, the shear bolt value must be changed. In fact, on a PTO size 80, the shear bolt is 12mm, grade 8 (10.9) for 540 RPM. Thus, it has to be changed to a shear bolt 7/16" dia. Grade 2 (6.6) for 1000 RPM.

IMPORTANT: The shear bolt cannot protect against all possible overloads. Unfortunately, snowblowers will be faced with forgotten or hidden objects under snow, such as : chain, tires, stones, pieces of wood, etc...In spite of all our efforts, machines are not built to resist all those conditions.

- B. Adjustment of the chain's tension**
After 10 working hours, the chain's adjustment must be checked. In order to do so, verify the backlash between the input and the output shaft by turning the input shaft in both directions while the output shaft remains still. If there is a play of 10 and 15, the chain must then be readjusted as follows:

- 1. Remove PTO from the chain box.**

2. **Unscrew the 13 bolts 5/16" dia. From covers around the input shaft on both sides of the chain box (6 bolts on each side).**

NOTE: Input shaft covers are eccentric with outside of covers. Therefore by turning input shaft cover, center to center distance of shafts will be changed and thus, this will adjust the chains tension.

3. **With a hammer and screw-driver or a chisel, gently turn both covers in the same direction until the nest hole of the cover is in line with the threaded hole of the chain box.**

IMPORTANT Make sure that the covers are turned in the same direction and by the same number of holes. Otherwise, both shafts will not be parallel and serious damages might arise,

4. **Verify the backlash between both shafts, as described in point B. If the difference is too high, repeat the operation explained in point 3. If the backlash is correct, reinstall the bolts and the PTO.**
5. **Verify the backlash every 100 working hours.**

C. After 25 working hours, it is recommended to drain the oil out of the chain box and fill it in with 2.6 litres of SAE 80W90 oil. Moreover, you will find, with the attached drawing illustrating the different parts of this chain box.

*****It is recommended to drain and change the oil every working season.*****

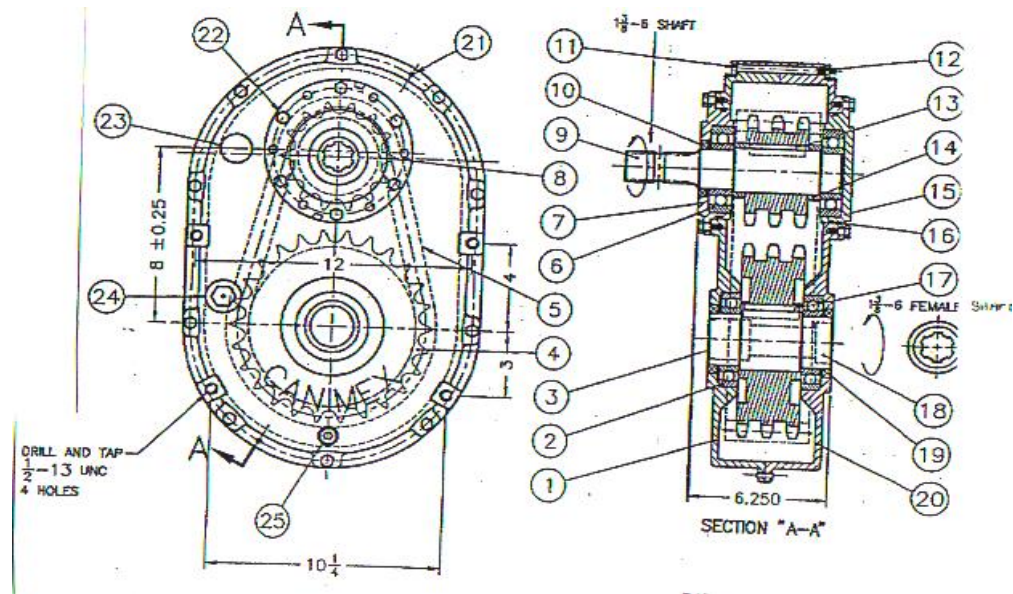

**Chainbox Assembly for T27D
(7',8' & 7 1/2' Pull-type)**

Pos.	Description	Material	Quantity	Drawing No.
1.	Casing with plug	Cast Iron	1	B-3858-2
2.	Bearing 6212	Standard	2	
3.	Seal Cover (47x7)	Standard	1	
4.	Sprocket 80-3A26	SAE 1045	1	B-3859-1
5.	Chain 80-3x36" L	Standard	1	
6.	Bearing 6309	Standard	2	
7.	Input cover with hole	Cast Iron	1	B-3869-2
8.	Sprocket 80-3A14	SAE 1045	1	B-3860-1
9.	Input shaft 1 3/8"x6 spline(010.036)	SAE 1045	1	B-3947-1
10.	Oil Seal (45x65x8) TC double lip	Standard	1	
11.	Bolt 5/16"-18 UNCx4 1/2"	Standard	10	
12.	Nut 5/16"-18UNC	Standard	10	
13.	Square Key 1/2"x2 1/2"	Standard	1	
14.	Spacer (2-2 3/8"-0.568)	SAE 1010	2	A-3862-2
15.	Input cover w/o hole	Cast Iron	1	B-4050-1
16.	O-ring as-248 (National)	Standard	2	
17.	Square key 3/8"x2 1/2"	Standard	1	
18.	Output shaft 1 3/8"x6 spline(010.039)	SAE 1045	1	B-3948-1
19.	Oil Seal (60x80x10)TC double lip	Standard	2	
20.	Casing w/o plug	Cast Iron	1	B-4051-1
21.	Slotted spring pin 3/16"x3/4"	Standard	2	
22.	Bolt 5/16"-18 UNC x3/4"	Standard	12	
23.	Air vent 1/2"-14 NPT	Standard	1	
24.	Sight glass 3/4"-14 NPT	Standard	1	
25.	Drain plug 1/2"-14 NPT	Standard	1	

All dimensions in inches except dimensions inside () in millimetres

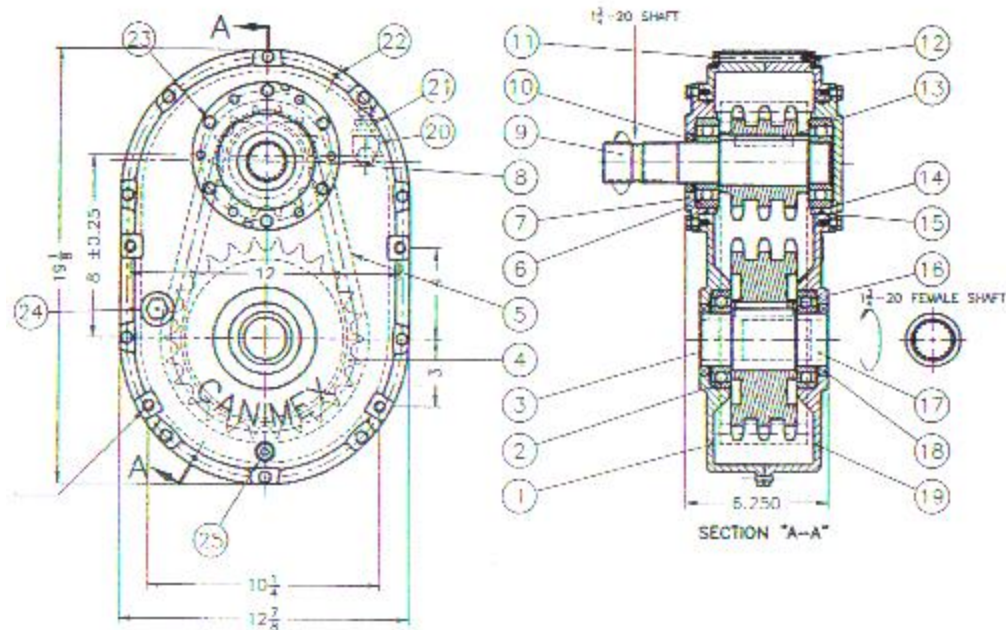

**Chainbox Assembly for T-279A
(8 1/2' & 9')**

Pos.	Description	Material	Quantity	Drawing No.
1.	Casing with plug	Cast Iron	1	B-3858-2
2.	Bearing 6212	Standard	2	
3.	Seal cover (47x7)	Standard	1	
4.	Sprocket 80-3A26	SAE 1045	1	B-3859-1
5.	Chain 80-3x36" L	Standard	1	
6.	Bearing 6309	Standard	2	
7.	Input cover with hole	Cast Iron	1	B-3869-2
8.	Sprocket 80-3A14	SAE 1045	1	B-3860-1
9.	Input shaft 1 3/4"x20 spline (010.038)	SAE 1045	1	B-3861-1
10.	Oil seal(45x65x8) TC double lip	Standard	1	
11.	Bolt 5/16"-18 UNC x 4 1/2"	Standard	10	
12.	Nut 5/16"-18 UNC	Standard	10	
13.	Square key 1/2"x2 1/2"	Standard	1	
14.	Spacer (2-2 3/8"-0.568)	SAE 1010	2	A-3852-2
15.	Input cover w/o hole	Cast Iron	1	B-4050-1
16.	O-ring as-248 (National)	Standard	2	
17.	Square key 5/8"x2 1/2"	Standard	1	
18.	Output shaft 1 3/4"-20 spline (010.037)	SAE 1045	1	B-3863-2
19.	Oil seal(60x80x10) TC double lip	Standard	2	
20.	Casing w/o plug	Cast Iron	1	B-4051-1
21.	Slotted spring pin 3/16"x3/4"	Standard	2	
22.	Bolt 5/16"-18 UNCx3/4"	Standard	12	
23.	Air vent 1/2"-14 NPT	Standard	1	
24.	Sight glass 3/4"-14 NPT	Standard	1	
25.	Drain plug 1/2"-14 NPT	Standard	1	